

FB—FOR FOOD AND BEVERAGE INDUSTRIES

Hygienic pumping solutions for various applications

Now, food industries can meet strict hygienic requirements with a sturdy sanitary pump brought to you by Grundfos. FB pumps are single-stage end-suction centrifugal pumps specially developed for food and beverage processors. These compact units are designed for flexible use, allowing many different processors to benefit from the pump's reliable performance.

Clever, compact design

FB pumps are made from AISI 316 stainless steel in a compact design which allows them to be highly mobile and easy to fit into any system. One of the features that permit this compact size is the plug-in shaft, which also provides easy service.

Based on strict standards

Sanitary processes call for high-quality solutions. In recognition of this, FB pumps are designed per the recommendations designated in the 3A sanitary standard and the European Hygienic Engineering Design Group (EHEDG). This is part of what makes them an ideal choice for food and beverage applications all over the world.

The FB is suitable for the following processes:

Beverage

Beer, soft drinks, alcohol, wine, fruit drinks, yeast, etc.

Dairy

Milk, whey, cream, condensed milk, etc.

Confectionery

Syrup, sugar solution, etc.

Meat packing

Liquid fat, frying oil, smokehouse spray, blood processing, etc.





Technical Data:

Head: up to 350 Feet
 Flow rate: up to 675 US GPM
 Operating pressure: up to 232 psi
 Operating temp: up to 203°F (302°F on request)
 Sterilization temp: 284°F (SIP)
 (Sterilization-In-Place)

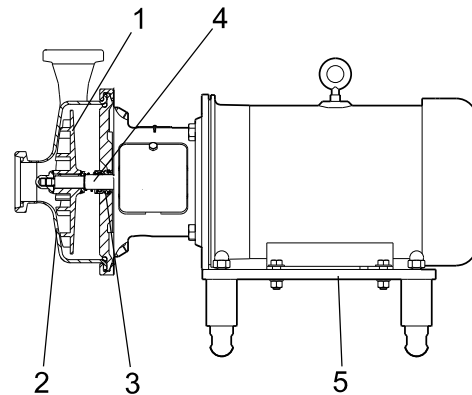

Materials

Pos.	Component	Material	EN DIN	AISI/ASTM
1	Impeller	CrNiMo steel	1.4404	316L
2	Pump Housing	CrNiMo steel	1.4404	316L
3	Shaft Seal	Seal faces: Carbon/stainless steel or SiC/SiC O-rings: EPDM or FKM		
4	Pump Shaft	CrNiMo steel	1.4571	316Ti
5	Feet and Support Bars	Stainless steel		

FB, 2-pole

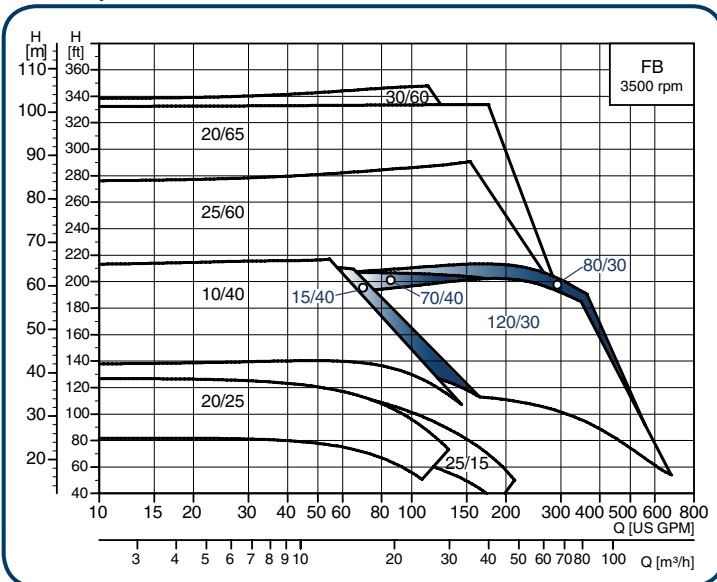

FB, 4-pole

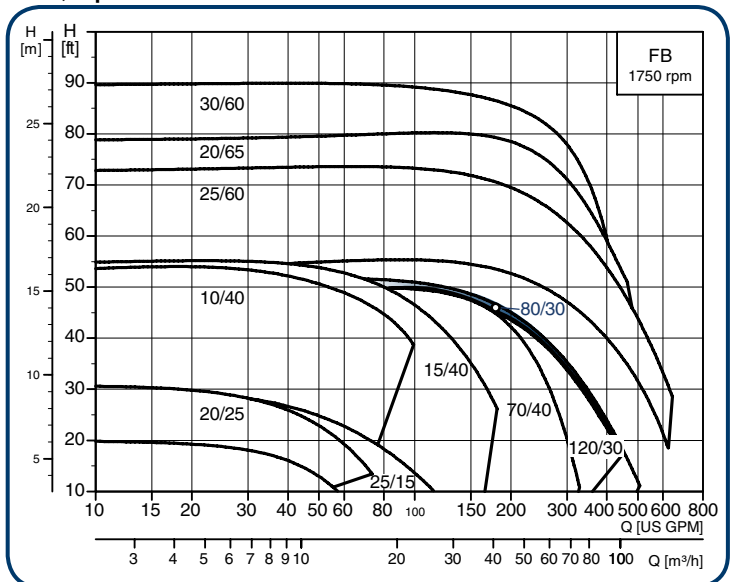

L-FB-SL-001 8/09 (US)

U.S.A.
GRUNDFOS Pumps Corporation
17100 West 118th Terrace
Olathe, Kansas 66061
Phone: (913) 227-3400
Telefax: (913) 227-3500

Canada
GRUNDFOS Canada Inc.
2941 Brighton Road
Oakville, Ontario
L6H 6C9
Phone: (905) 829-9533
Telefax: (905) 829-9512

Mexico
Bombas GRUNDFOS de Mexico S.A. de C.V.
Boulevard TLC No. 15
Parque Industrial Stiva Aeropuerto
C.P. 66600 Apodaca, N.L. Mexico
Phone: 011-52-81-8144 4000
Telefax: 011-52-81-8144 4010

www.grundfos.us/industry

