



Thermal Fluid Heaters

Vertical Coil, Vertical Tubeless, Electric and Horizontal
Sizes from 75,000 to 40,000,000 BTU/HR

**RUGGED
ROBUST
RELIABLE**



The heat transfer innovators.

THERMAL FLUID FEATURES AND BENEFITS

KEY FEATURES

- No Corrosion or Freezing
- High Operating Temperatures (up to 750° F) with Low System Pressure
- Minimum Maintenance - Burner, Pump and Controls
- Simple Circuit; No Blow-Downs, Steam Traps or Condensate Return Systems
- Fulton's Combination Expansion / Deaerator Thermal Buffer Tank Provides Pipework Simplification, Protection of Thermal Fluid from Oxidation and Continuous Deaeration of Fluid to Avoid Pump Cavitation
- Heaters are Built and Tested to ASME Code Section VIII Div. I as standard. ASME Code Section I is available upon request
- Fulton Heaters are Manufactured Individually for Maximum Flexibility and to Customer Specifications
- Fulton Heaters and Accessory Components (Pumps, Expansion Tanks, Control Valves, etc.) Can Be Skid Mounted to Save Time and On-Site Fabrication

THERMAL FLUID VS. STEAM

A thermal fluid (hot oil) system operates in a closed loop circulation system with minimal pressure. Fulton thermal fluid systems can reach 750° F (345° C) making them an ideal choice for many process heat applications.

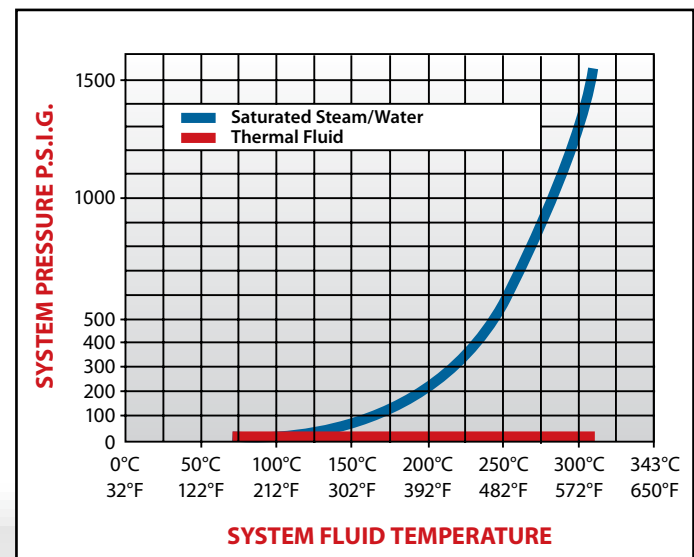

The choice between a steam system or a thermal fluid system is governed by the process requirements. The range or process temperature is a deciding factor. If the system's required temperature is above the freezing point of water (32° F) and below approximately 350° F, the choice is usually steam. However, if the required temperature is below 32° F or above 350° F, thermal fluid may be a better solution.

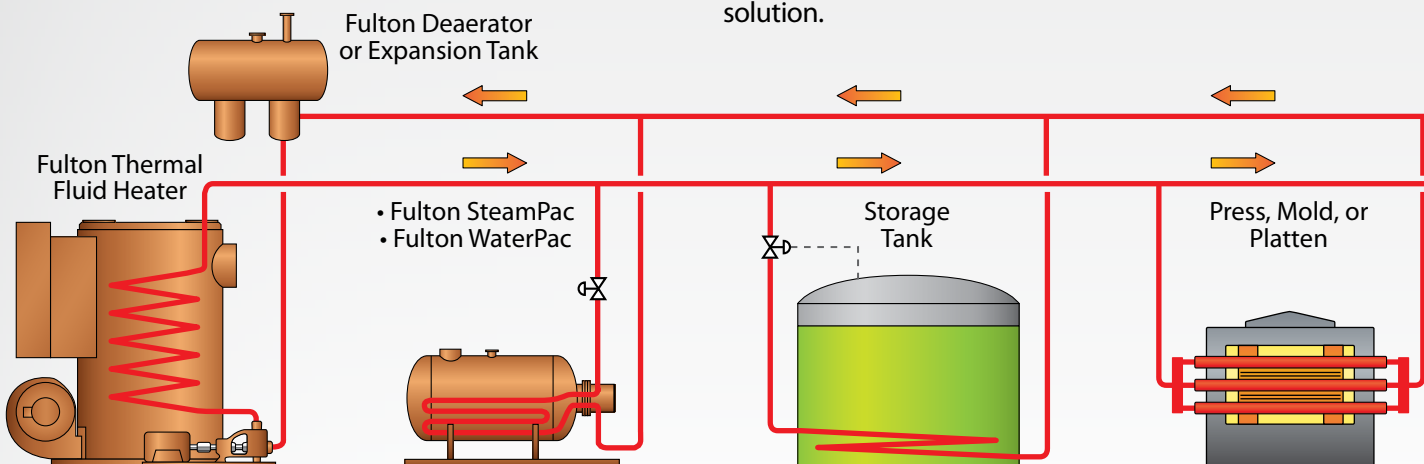

APPLICATIONS



Fulton heaters are used in a variety of applications throughout many industries. Food, plastic and chemical processing, as well as pharmaceutical and bio-fuel production, are only a few examples of the many existing applications using Fulton equipment.



- Adhesives
- Asphalt
- Autoclaves
- Bio-fuel
- Chemical Reactors
- Deodorization
- Distillation
- Food Processing (frying, baking, etc.)
- Gas Processing / Oil Processing
- Inks & Dyes
- Laminating
- Laundry
- Marine Heating and Shipboard Services
- Metal Finishing
- Mining
- Ovens
- Paint and Varnish Manufacture
- Paper Converting Machinery
- Plastics
- Printing and Packaging Machinery
- Rubber and Rubber Compounds
- Surface Pre-Treatment and Finishing
- Tank Farms/Pipe and Pump Tracing
- Textile Machinery
- Unfired Steam or Hot Water Generation
- Uranium Processing
- Waste Treatment/Dryers

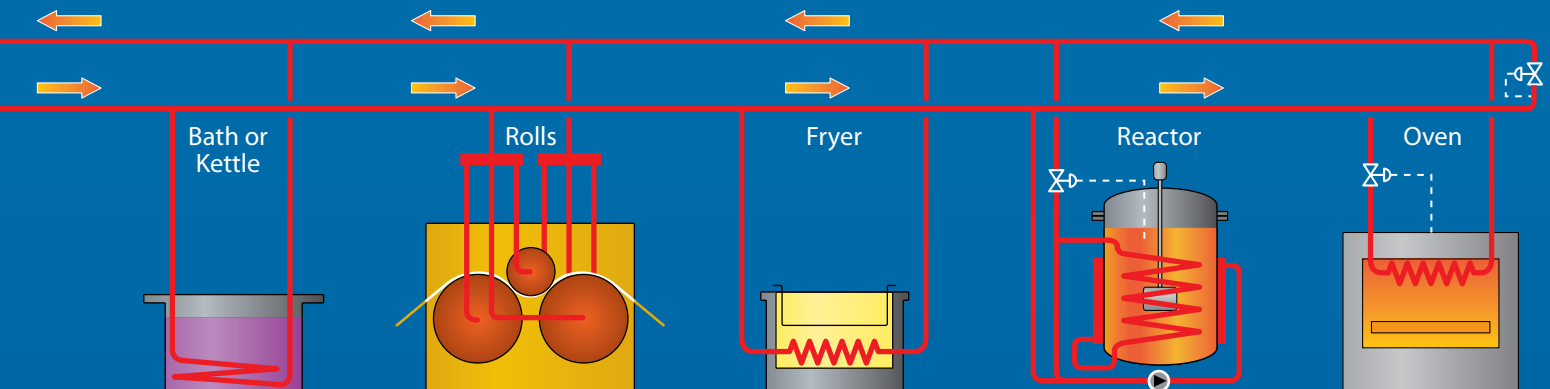

G-MODEL VERTICAL COIL DESIGN

KEY FEATURES

- Vertical 4-Pass Design
- Preheated Combustion Air is an Integral Part of the Design
- Heaters are Built and Tested to ASME Code Section VIII Div. I as standard. ASME Code Section I is available upon request
- 800,000 BTU/Hr to 14,000,000 BTU/Hr Output
- Operating Temperatures to 750° F
- Gas, Oil or Dual Fuel Burners; On/Off or Modulating
- Low Emission Natural Gas Burners are Available
- Minimal Refractory Results in Low Thermal Inertia and Prevents Overheating of the Fluid in the Event of a Pump or Power Failure
- Customized Controls Available
- Customized Heaters Available
- High Efficiencies
- Even Heating

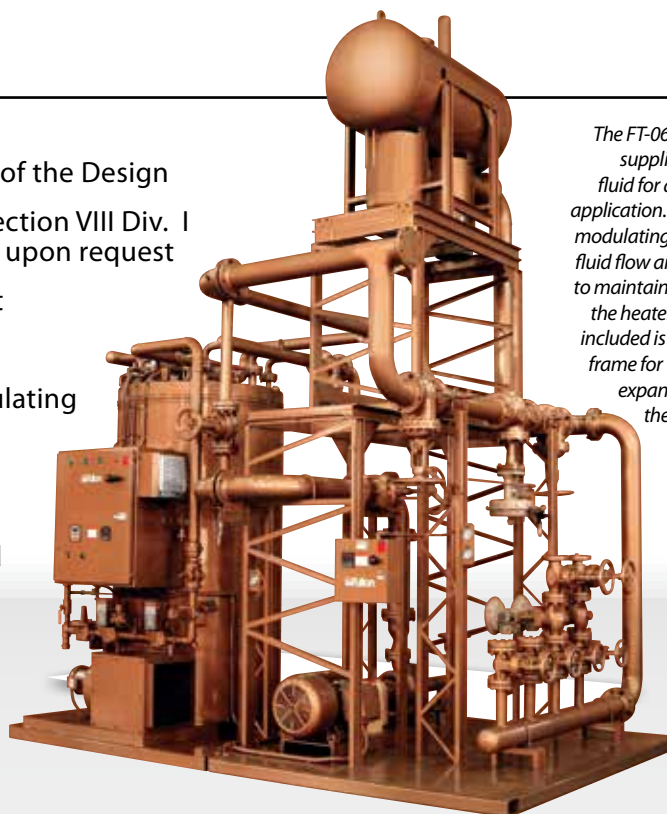

The FT-0600-C shown here supplies 600° F thermal fluid for a food processing application. The skid includes modulating valves to control fluid flow and a bypass valve to maintain flow throughout the heater at all times. Also included is a custom 3-piece frame for the top-mounted expansion / deaerator / thermal buffer tank.

MODELS	FT-C	0080	0120	0160	0240	0320	0400	0600	0800	1000	1200	1400
Specifications												
Heat Output	1,000 BTU/HR	800	1,200	1,600	2,400	3,200	4,000	6,000	8,000	10,000	12,000	14,000
	1,000 KCAL/HR	200	300	400	600	800	1,000	1,500	2,000	2,500	3,000	3,500
Thermal Fluid Content	Gallons	10	21	19	31	68	76	132	201	290	383	460
	Liters	38	80	72	116	258	288	498	648	1,097	1,448	1,741
Recommended Flow Rate	GPM	50	75	100	150	250	250	375	500	615	730	800
	M3/HR	11.4	17	22.7	34	56.8	56.8	85.2	113.6	139	167	182
Approximate Fuel Usage												
Light Oil *	GPH	7.1	10.7	14.3	21.4	28	35.3	53	69.3	87.1	104.5	122
	LPH	27	40.6	54.1	81	108.8	136	201	263.7	329.6	395.5	461.5
Natural Gas *	FT3/HR	998	1,498	1,998	2,999	4,000	4,997	7,498	9,997	12,496	14,998	17,500
	M3/HR	38.3	42.4	56.5	84.9	113.2	141.5	212.3	283	353.8	424.6	495.5
Power												
Typical Circulating Pump	HP	10	10	15	15	20	20	30	40	50	50	60
	KW	7.5	7.5	11.2	11.2	14.9	14.9	22.5	29.5	37.3	37.3	45
Typical Burner Motor	HP	1.5	3	3	3	5	7.5	7.5	15	20	20	20
	KW	1.1	2.2	2.2	2.2	3.7	5.6	5.6	11.2	11.2	15	15

* Please consult factory for additional fuel options. Fuel up to No. 6 Oil available for large units (FT-0600-C and larger). Voltage 3 Phase for Burner and Pump - Each unit has an incorporated step down transformer. Efficiency up to 80% Minimum Based on High Heating Value of the Fuel (No. 2 Oil @ 140,000 BTU/GHHV; Natural Gas @ 1,000 BTU/ft³HHV) Circulating pump motor sizes based on standard pressure (55 PSIG) and viscosity 1 cs, specific gravity 0.7, with 25-37 PSID available head for installation. All Units are Modulated. Operating specifications may change based on field conditions.

A LOOK INSIDE

THE COMBUSTION PROCESS

1 The combustion air enters the burner fan inlet, travels upward between the inner and outer jacket, preheating the air before it enters the top mounted burner.

2 Hot gases travel down the full length of the vessel creating the first (radiant) pass.

3 The gases then travel back across the inner row of coils, creating the second (convection) pass.

4 The third (convection) pass is created as the gases continue back down between the inner and outer coil.

5 The last pass is upward between the outer coil and inner jacket to the flue outlet, creating the fourth (convection) pass.

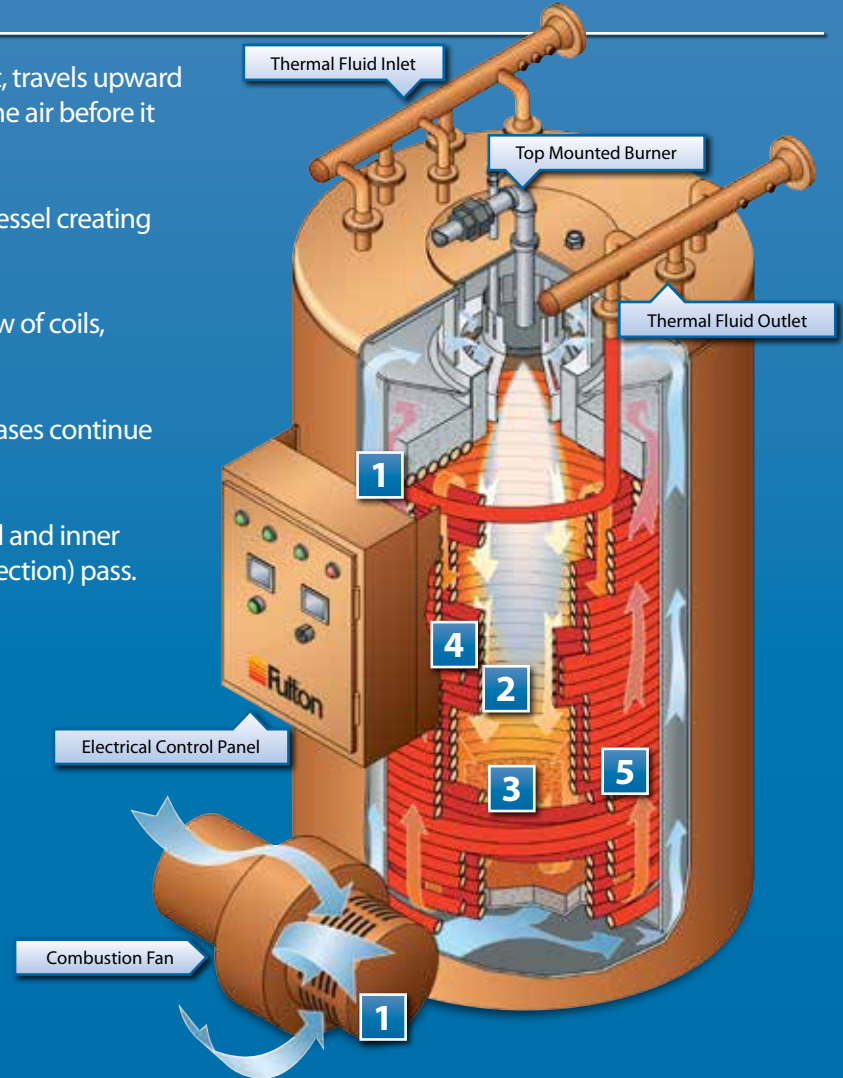
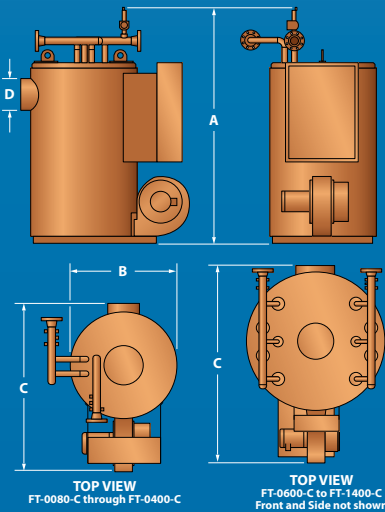

MODELS	FT-C	0080	0120	0160	0240	0320	0400	0600	0800	1000	1200	1400
Dimensions												
Heater Inlet/Outlet Connections	IN	1.25	1.5	2	2.5	3	3	4	4	6	6	6
	MM	32	38	51	64	76.3	76	102	102	152	152	152
(A) Overall Height	IN	73.7	80.7	80.6	89.7	100.6	112.4	143.6	143	146.5	146.4	163.1
	MM	1,872	2,050	2,046	2,278	2,556	2,856	3,648	3,632	3,721	3,718	4,144
(B) Heater Width	IN	31.6	34.4	45.9	50.1	49.3	49.3	63.4	70.5	95	108.4	108.4
	MM	803	873	1,165	1,273	1,252	1,252	1,611	1,791	2,413	2,753	2,753
(C) Overall Depth	IN	46.2	60.6	60.6	66.6	80.6	80.6	88.1	107.75	135.1	152.9	152.9
	MM	1,173	1,540	1,540	1,691	2,046	2,046	2,237	2,736	3,432	3,882	3,882
(D) Flue Outlet Diameter	IN	10	10	10	12	14	14	18	20	20	22	22
	MM	254	254	254	305	356	356	457	508	508	559	559
Recommended Stack Diameter	IN	10	12	12	14	18	18	22	24	24	26	26
	MM	254	304	304	356	457	457	558	609	609	661	661
Approximate Dry Weight	LB	1,500	2,100	2,550	3,400	5,300	5,300	8,250	11,450	19,250	21,700	23,000
	KG	700	950	1,150	1,550	2,400	2,400	3,750	5,200	8,750	9,850	10,455

Specifications and Dimensions are approximate. Consult factory for model specific electrical requirements. We reserve the right to change specifications and/or dimensions without notice. Diagram for guidance purposes only. Comprehensive details of dimensions, connections, etc. for each model are given on product dimension data sheets available from Fulton.

A-MODEL

VERTICAL TUBELESS DESIGN

KEY FEATURES

- Vertical Annular Design
- Heaters are Built and Tested to ASME Code Section VIII Div. I as standard. ASME Code Section I is available upon request
- 207,000 BTU/Hr to 1,736,000 BTU/Hr Output
- Operating Temperatures to 600° F
- Gas or Oil Fired Burners, On/Off or Modulating
- Low Emission Gas Burners are Available
- Customized Controls Available
- Customized Heaters Available



Pictured here is a skid mounted FT-0690-A thermal fluid heater with a deaerator / thermal buffer tank and a circulation pump.

MODELS	FT-A	0200	0380	0520	0690	1050	1740
Specifications							
Heat Output	1,000 BTU/HR	207	348	519	693	1,052	1,736
	1,000 KCAL/HR	52	88	131	175	265	437
Thermal Fluid Content	Gallons	23	38	45	65	98	117
	Liters	87	144	170	246	371	443
Recommended Flow Rate	GPM	90	90	125	125	150	200
	M3/HR	21	21	28	28	34	46
Approximate Fuel Usage • Light Oil	GPH	2.2	3.2	4.7	6.7	9.4	15.8
	LPH	8.3	11.9	17.8	25.4	35.6	60
Approximate Fuel Usage • Natural Gas	FT3/HR	259	435	649	866	1,315	2,170
	M3/HR	7.2	12.2	18.4	24.2	36.8	60.8
Power							
Typical Circulating Pump	HP	10	10	15	15	15	20
	KW	7.5	7.5	11.2	11.2	11.2	14.9
Typical Burner Motor	HP	.33	.33	.33	.75	.75	1.5
	KW	.248	.248	.248	.56	.56	1.1

A LOOK INSIDE

THE COMBUSTION PROCESS

1 The top-mounted down-fired burner delivers a spinning flame down the length of the furnace. As the flame swirls downward in a controlled flow pattern, the fluid spirals upward in the pressure vessel.

2 Hot gases from the flame are carried up the outside of the vessel in the secondary flue passage convection area.

3 Convection fins welded along the full length of the vessel transmit the remaining heat through the outer side of the fluid vessel and into the fluid. The result is even heating of thermal fluids for optimum thermal efficiency.

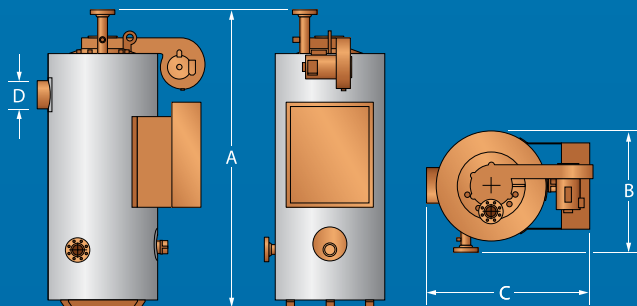
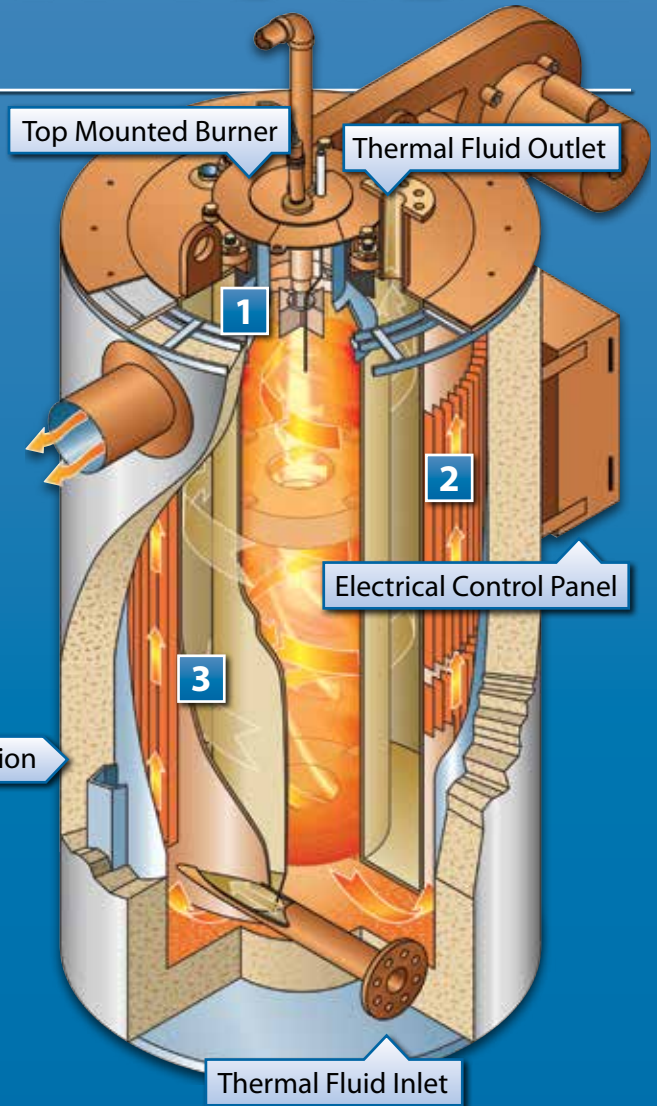

Specifications and Dimensions are approximate. Consult factory for model specific electrical requirements. We reserve the right to change specifications and/or dimensions without notice.

Diagram for guidance purposes only. Comprehensive details of dimensions, connections, etc. for each model are given on product dimension data sheets available from Fulton.

MODELS	FT-A	0200	0380	0520	0690	1050	1740
Dimensions							
Heater Inlet/Outlet Connections	IN	1.5	1.5	2	2	2	2.5
	MM	38	38	51	51	51	64
(A) Overall Height	IN	69	75	85	86	86	110
	MM	1,752	1,905	2,159	2,185	2,185	2,794
(B) Heater Width	IN	26	28	30	36	44	44
	MM	660	710	760	915	1,120	1,120
(C) Overall Depth	IN	43	45.5	46	56	64	64
	MM	1,092	1,156	1,168	1,422	1,626	1,626
(D) Flue Outlet Diameter	IN	6	6	8	10	12	12
	MM	152	152	203	254	305	305
Approximate Dry Weight	LB	1,850	2,100	2,300	3,400	4,400	7,200
	KG	840	955	1,045	1,540	1,995	3,275

N-MODEL

VERTICAL ELECTRIC DESIGN

KEY FEATURES

- Compact Vertical Design
- Heaters are Built and Tested to ASME Code Section VIII Div. I as standard. ASME Code Section I is available upon request
- 74,000 BTU/Hr to 1,685,000 BTU/Hr Output
- Operating Temperatures to 650° F
- Low Watt Density Elements Result in Low Film Temperatures and Long Element Life
- Customized Controls Available, Including (but not limited to) Class 1, Division 1 or 2 groups C&D of NEC Code
- Customized Heaters Available



Pictured here is a skid mounted FT-0640-N electric thermal fluid heater with an expansion / deaerator / thermal buffer tank and a circulation pump.

MODELS	FT-N	0075	0150	0225	0300	0375	0430	0640	0860	1070	1290	1500	1720
Specifications													
	KW	22	44	66	88	110	126	189	252	315	378	441	504
Heat Input	1,000 BTU/HR	75	150	225	300	375	429	644	859	1,074	1,289	1,504	1,719
	1,000 KCAL/HR	18.9	37.8	56.7	75.6	94.5	108	162	216	271	325	379	433
Heat Output	1,000 BTU/HR	74	148	222	294	368	420	631	842	1,053	1,263	1,474	1,685
	1,000 KCAL/HR	18.6	37.3	59.9	74.1	92.7	105.8	159	212.2	265.4	318.3	371.4	424.6
Thermal Fluid Content	Gallons	18	36	42	54	63	79	79	102	127	152	168	185
	Liters	68	136	159	204	238	299	299	386	480	575	636	700
Recommended Flow Rate	GPM	50	50	50	90	90	125	125	150	150	175	200	200
	M3/HR	11.4	11.4	11.4	20.5	20.5	28.4	28.4	34	34	39.8	45.5	45.5
Power													
Typical Circulating Pump Motor	HP	7.5	7.5	7.5	10	10	15	15	15	15	15	20	20
	KW	5.6	5.6	5.6	7.5	7.5	11.2	11.2	11.2	11.2	11.2	14.9	14.9
Amps	208V	61	122	183	245	306	350	525	700	875	1,050	1,224	1,399
	220V	53	106	159	212	265	303	455	607	758	910	1,061	1,212
	480V	26	53	79	106	132	151	228	303	379	455	531	606

A LOOK INSIDE

OPERATING PRINCIPLE

- 1** Thermal fluid enters the heater from the lower right side. This unique circulation method (upward spiraling fluid) results in an even flow of thermal fluid within the vessel.
- 2** The thermal fluid flows evenly across the multiple low watt density elements, uniformly heating the thermal fluid. This results in low film temperatures and assures long element life.
- 3** Fulton electric thermal fluid heaters are nearly 100% efficient because the elements are totally immersed in thermal fluid and the jacket is fully insulated with high density insulation.

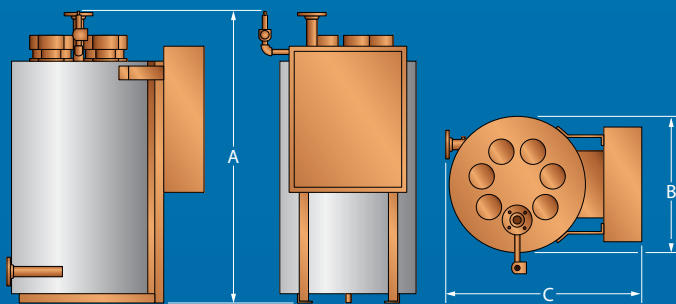
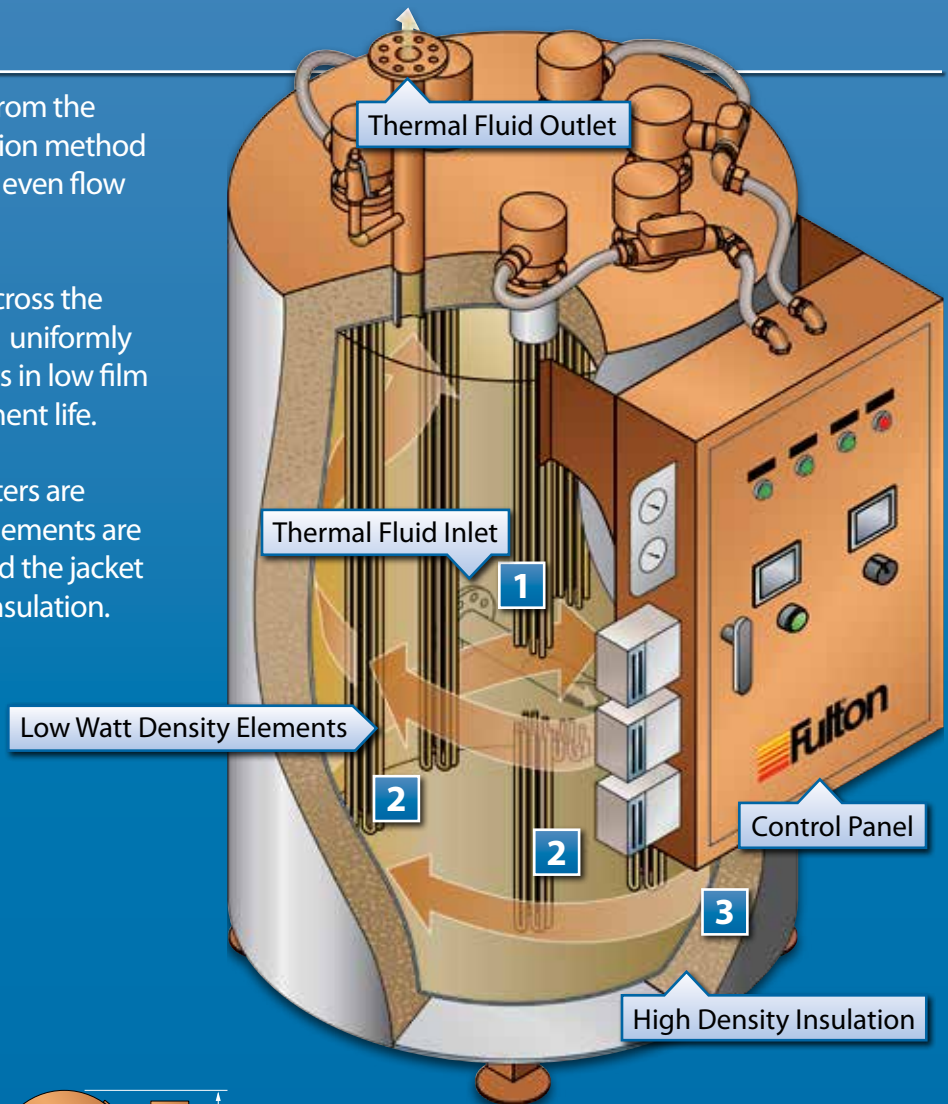

Specifications and Dimensions are approximate. Consult factory for model specific electrical requirements. We reserve the right to change specifications and/or dimensions without notice. Diagram for guidance purposes only. Comprehensive details of dimensions, connections, etc. for each model are given on product dimension data sheets available from Fulton.

MODELS	FT-N	0075	0150	0225	0300	0375	0430	0640	0860	1070	1290	1500	1720
Dimensions													
Heater Inlet	IN	1.5	1.5	1.5	1.5	1.5	2	2	2	2	2	2.5	2.5
	MM	38	38	38	38	38	51	51	51	51	51	64	64
(A) Overall Height	IN	70	70	70.5	70	70	90.5	90.4	90.8	89.8	91.2	93	93
	MM	1,778	1,778	1,791	1,778	1,778	2,299	2,296	2,306	2,281	2,317	2,362	2,362
(B) Heater Width	IN	20	26	28	32	32	32	32	38	44	50	54	58
	MM	508	660	711	813	813	813	813	965	1,118	1,270	1,372	1,473
(C) Overall Depth	IN	37.5	43	43.5	47.5	47.5	47.5	49.5	53.8	58.4	65.7	71.8	75.7
	MM	953	1,092	1,105	1,207	1,207	1,207	1,257	1,365	1,257	1,669	1,823	1,993
Approximate Dry Weight	LB	1,060	1,220	1,400	1,540	1,660	2,040	2,200	2,370	2,650	2,950	2,950	3,600
	KG	481	555	636	700	756	927	1,000	1,077	1,205	1,341	1,341	1,636

HOPKINS

HORIZONTAL COIL DESIGN

KEY FEATURES

- Horizontal 2-Pass Design
- 1,000,000 BTU/Hr to 40,000,000 BTU/Hr Output
- Heaters are Built and Tested to ASME Code Section VIII Div. I as standard. ASME Code Section I is available upon request
- Operating Temperatures to 650° F
- Modulating Gas, Oil or Dual Fuel Burners
- Alternative Fuel Capabilities
- Open Protocol Burner
- Skid-Mounted Systems Available, Including Circulating Pump and Expansion Tank
- Customized Controls and Coil Designs Available
- Water - Glycol Heaters Available
- Available With or Without Integral Expansion Tank



MODELS	HPN	100S	200S	350S	600S	800S	1000S	1200S	1400S	1600S	2000S	2400S	3000S	4000S
Specifications														
Heat Output	Million BTU/hr	1	2	3.5	6	8	10	12	14	16	20	24	30	40
	Million Kcal/hr	.25	.5	.875	1.5	2	2.5	3	3.5	4	5	6	7.5	10
Flow Rate-Standard *1	GPM	75	150	265	425	600	725	900	1050	1200	1500	1800	2250	3000
	M3/min	18	35	61	97	137	165	205	239	273	341	409	511	682
Flow Rate-Low Flow *2	GPM	40	75	135	225	300	375	450	525	600	750	900	1125	1500
	M3/min	10	18	31	52	69	86	103	120	97	171	205	256	341
Circulating Pump Motor-STD	HP	7.5	15	20	30	40	50	60	75	100	100	125	150	200
	kW	5.6	11.2	14.9	22.5	29.8	37.3	45	56	74.5	74.5	93.2	111.8	149
Circulating Pump Motor-LF	HP	7.5	7.5	15	20	30	30	40	30	40	50	60	75	100
	kW	5.6	5.6	11.2	14.9	22.5	22.5	29.8	22.5	29.8	37.3	45	56	74.5
Blower Motor	HP	1/3	1	2	7.5	10	10	5	7.5	7.5	15	20	25	30
	kW	.25	.7	1.5	5.6	7.5	7.5	4.3	5.6	5.6	11.2	14.9	18.6	22.5
Light Oil (approx. fuel usage)*3	GPH	8.8	17.5	30.6	52.5	70	87.5	104.9	122.4	139.9	174.9	209.8	262.3	349.7
	LPH	33.3	66.2	115.8	198.7	265	331.2	397	463.3	529.5	662	794	992.8	1324
Natural Gas (approx. fuel usage)*3	FT3/hr	1,334	2,667	4,667	8,000	10,667	13,334	16,000	18,667	21,334	26,667	32,000	40,000	53,334
	M3/hr	37.4	75	131	224	299	373.4	448	522.7	597.4	747	896	1120	1493.4

A LOOK INSIDE

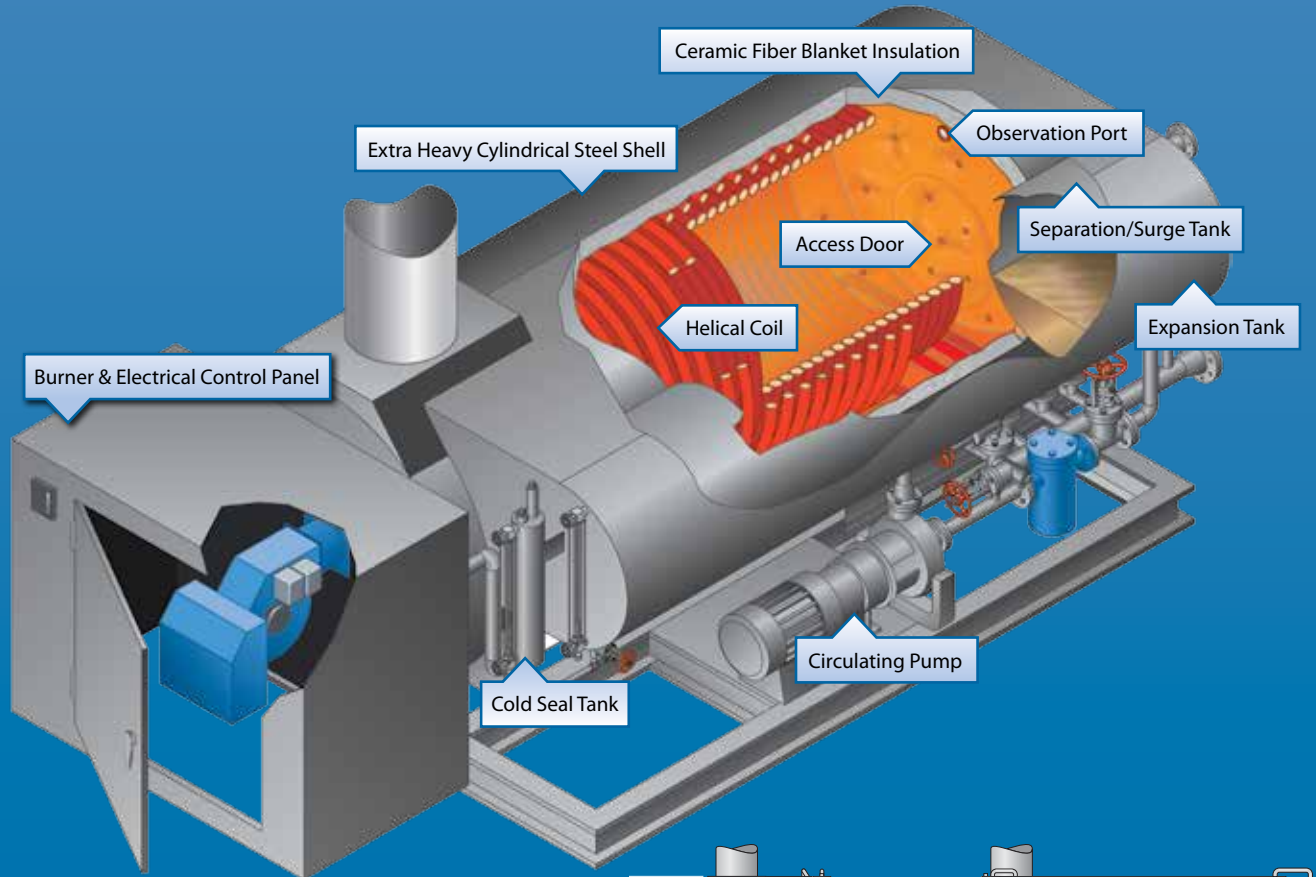

Specifications and Dimensions are approximate. Consult factory for model specific electrical requirements. We reserve the right to change specifications and/or dimensions without notice.

Diagram for guidance purposes only. Comprehensive details of dimensions, connections, etc. for each model are given on product dimension data sheets available from Fulton.

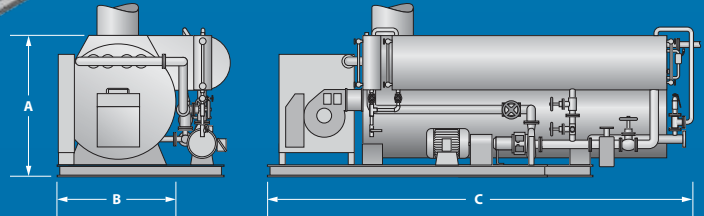

***NOTE:** Dimensions shown are for the Hopkins model without the integral expansion tank.

MODELS		HPN	100S	200S	350S	600S	800S	1000S	1200S	1400S	1600S	2000S	2400S	3000S	4000S
Dimensions															
(A) Overall Height (w/o Stack)	IN	51	60	62	82	82	105	105	106	106	125	133	133	142	
	MM	1,295.4	1,524	1,575	2,083	2,083	2,667	2,667	2,692.4	2,692.4	3,175	3,378	3,378	3,607	
(B) Overall Width	IN	42	50	50	74	93	87	103	110	110	123	130	130	142	
	MM	1,067	1,270	1,270	1,880	2,362	2,210	2,617	2,794	2,794	3,124	3,302	3,302	3,607	
(C) Overall Length	IN	115	152	211	231	302	311	360	408	444	450	550	575	648	
	MM	2,921	3,861	5,359	5,867	7,671	7,899	9,144	10,363	11,278	11,430	13,970	14,605	16,459	
Inlet/Outlet Connections	IN	2	3	3	4	6	6	8	8	8	10	12	12	12	
	MM	51	76.2	76.2	102	152.4	152.4	203	203	203	254	305	305	305	
Thermal Liquid Volume	Gallons	45	86	168	426	661	724	853	1,168	1,400	1,721	2,322	3,180	4,626	
	Liters	170	325	635	1,612	2,502	2,740	3,228	4,421	5,299	6,514	8,789	12,037	17,511	
Approx. Dry Weight	LB	3,936	6,800	9,052	14,350	18,500	23,100	26,800	30,500	32,600	41,400	68,000	74,000	80,000	
	KG	1,785	3,084	4,106	6,509	8,392	10,478	12,156	13,835	14,787	18,779	30,844	33,566	36,287	
Approx. Flooded Weight	LB	4,310	7,514	10,447	17,886	23,987	29,110	33,880	40,195	44,220	55,685	87,273	100,394	118,396	
	KG	1,955	3,408	4,739	8,113	10,880	13,204	15,368	18,232	20,058	25,258	39,586	45,538	53,704	
Floor Loading	LB/FT ³	129	143	143	151	123	155	132	129	131	145	176	194	186	
	KG/M ³	2,066	2,291	2,291	2,419	1,970	2,483	2,115	2,066	2,099	2,323	2,819	3,108	2,980	

ALLIANCE

HORIZONTAL COIL DESIGN

KEY FEATURES

- Compact Horizontal 3-Pass Design
- 2,400,000 BTU/Hr to 20,000,000 BTU/Hr Output
- Heaters are Built and Tested to ASME Code Section VIII Div. I as standard. ASME Code Section I is available upon request.
- Operating Temperatures to 650° F
- Modulating Gas, Oil or Dual Fuel Burners
- Low Emission Gas Burners
- Alternative Fuel Capabilities
- Open Protocol Burner
- Skid Mounted Systems Available, Including Circulating Pump and Expansion Tank
- Customized Controls and Heaters Available

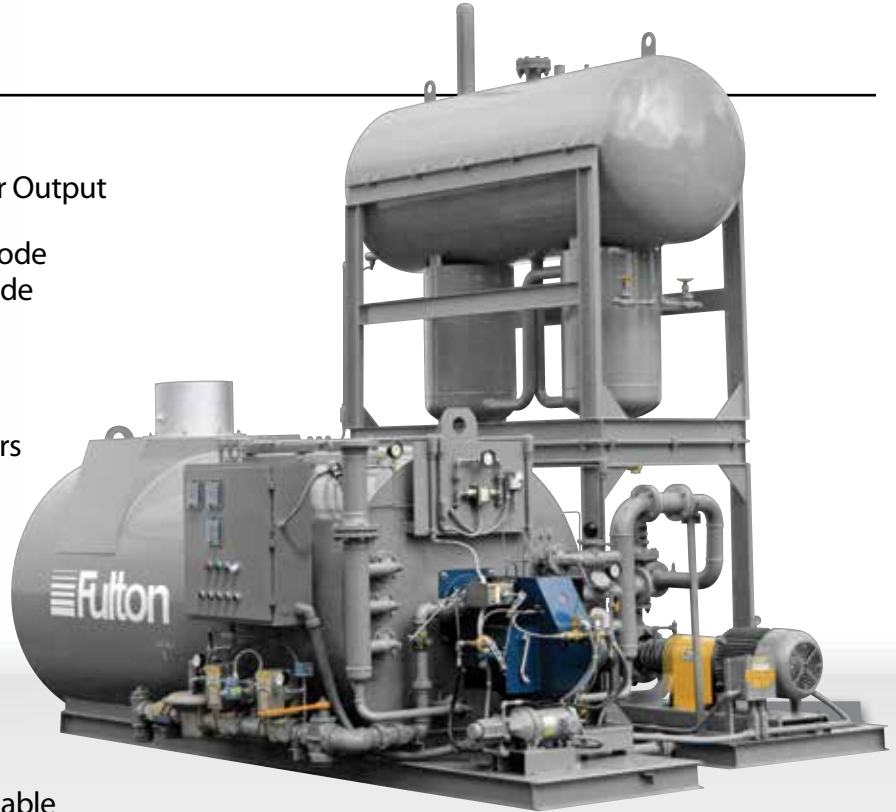

Shown here is an FT-0600-HC horizontal heater skid mounted with circulation pump and a combination expansion / deaerator / thermal buffer tank, designed for barge cargo heating.

MODELS	HC	0240	0400	0600	0800	1000	1200	1600	2000
Specifications									
Heat Output	1,000 BTU/HR	2,400	4,000	6,000	8,000	10,000	12,000	16,000	20,000
	1,000 KCAL/HR	600	1,000	1,500	2,000	2,500	3,000	4,032	5,040
Thermal Fluid Content	Gallons	75	115	190	264	325	508	480	1,150
	Liters	284	435	719	998	1,230	1,921	1,817	4,353
Recommended Flow Rate	GPM	150	300	400	600	850	1,200	1,200	1,500
	M3/HR	35	69	91	137	193	273	273	341
Approximate Fuel Usage									
Light Oil	GPH	23	39	58	77	96	115	143	179
	LPH	88	148	220	292	364	436	542	678
Natural Gas	FT3/HR	3,200	5,340	8,000	10,700	13,340	16,000	20,000	25,000
	M3/HR	91	152	227	304	378	454	566	708
Power									
Typical Circulating Pump Motor	HP	15	25	30	50	60	75	100	125
	KW	11.2	18.7	22.5	37.3	45	56	74.5	93.2
Typical Burner Motor	HP	2	5	7.5	10	15	15	30	30
	KW	1.5	3.7	5.6	7.5	11.2	11.2	22.4	22.4

A LOOK INSIDE

THE COMBUSTION PROCESS

1 Air and fuel mix in the open protocol burner located at the front of the heater. The burner fires down the center of the vessel forming the first pass.

2 The hot gases turn at the rear of the vessel and return between two rolls of coils to the front end plate forming the second pass.

3 The hot gases then flow along the outside of the coils to the back of the heater, forming the third pass and then exit out the flue.

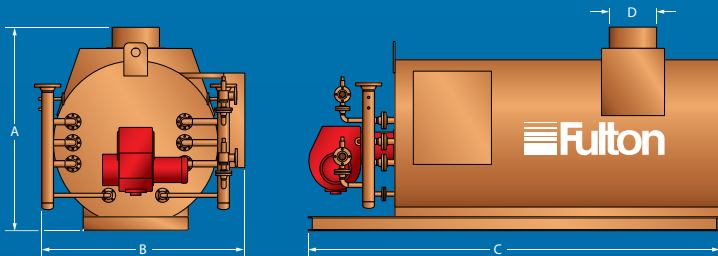
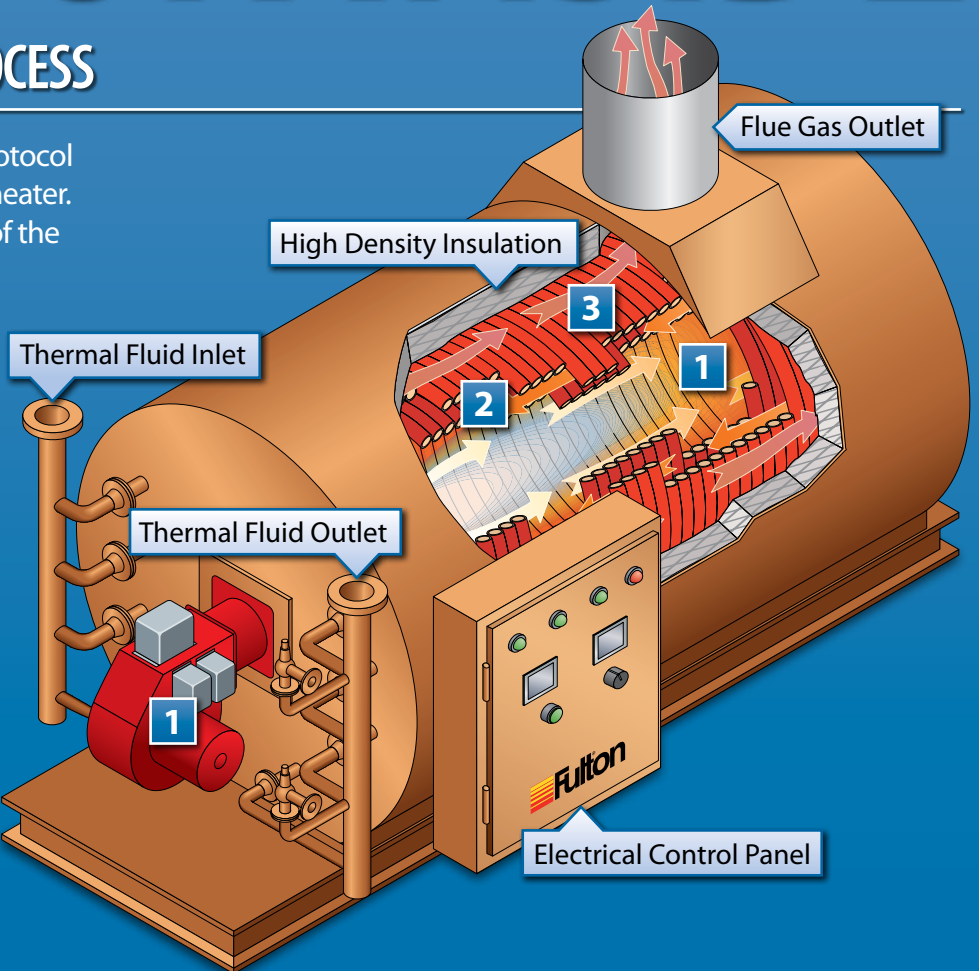

Specifications and Dimensions are approximate. Consult factory for model specific electrical requirements. We reserve the right to change specifications and/or dimensions without notice.

Diagram for guidance purposes only. Comprehensive details of dimensions, connections, etc. for each model are given on product dimension data sheets available from Fulton.

MODELS	HC	0240	0400	0600	0800	1000	1200	1600	2000
Dimensions									
Heater Inlet/Outlet Connections	IN	2.5	3	4	6	6	6	8	8
	MM	64	76	102	152	152	152	203	203
(A) Overall Height	IN	64	68	78	107	107	131	114	118
	MM	1,626	1,727	1,981	2,718	2,718	3,327	2,896	2,997
(B) Heater Width	IN	62	62	81	95	95	130	118.5	119.5
	MM	1,575	1,575	2,057	2,413	2,413	3,302	3,010	3,035
(C) Overall Depth	IN	134	137	157	208	182	240	327	351
	MM	3,404	3,480	3,988	4,623	4,623	6,096	8,306	8,915
(D) Flue Outlet Diameter	IN	12	14	18	22	22	22	36	36
	MM	305	356	457	559	559	559	914	914
Approximate Dry Weight	LB	5,000	7,500	9,500	12,500	19,250	21,700	39,000	39,000
	KG	2,272	3,409	5,455	5,682	8,750	9,864	17,728	17,728

UNFIRED STEAM AND HOT WATER GENERATORS

STEAM GENERATOR KEY FEATURES

- Vertical Design 10 HP to 100 HP
- Horizontal Design 70 HP to 415 HP (Custom sizes are available)
- Standard Designs 15 PSIG to 150 PSIG (custom operating pressures are available)
- Built and Stamped to ASME Code Section VIII Div. I
- Complete with Modulating Thermal Fluid Control Valve and Custom Control Panel
- May be Skid Mounted with Blowdown Separators, Return Tanks, Deaerator Tanks, Feedwater Pumps, Chemical Tanks and Water Softeners



HOT WATER GENERATOR KEY FEATURES

- Custom Designs Available
- Carbon Steel or Stainless Steel
- Built and Stamped to ASME Code Section VIII Div. I
- Complete with Modulating Thermal Fluid Control Valve
- Instantaneous Hot Water Generation, or Can Be Used with a Storage Tank



EXPANSION/DEAERATOR/THERMAL BUFFER TANK

KEY FEATURES

- Designed to Work as an Open-Atmospheric System Where Applicable, Eliminating the Expense of an Inert Gas Blanket
- Continuous Deaeration of Steam and Other Non-Condensibles
- Protects Fluid from Oxidation
- Simplification of Pipework
- Ease of Installation
- Standard 2-Pipe Expansion Tanks also Available

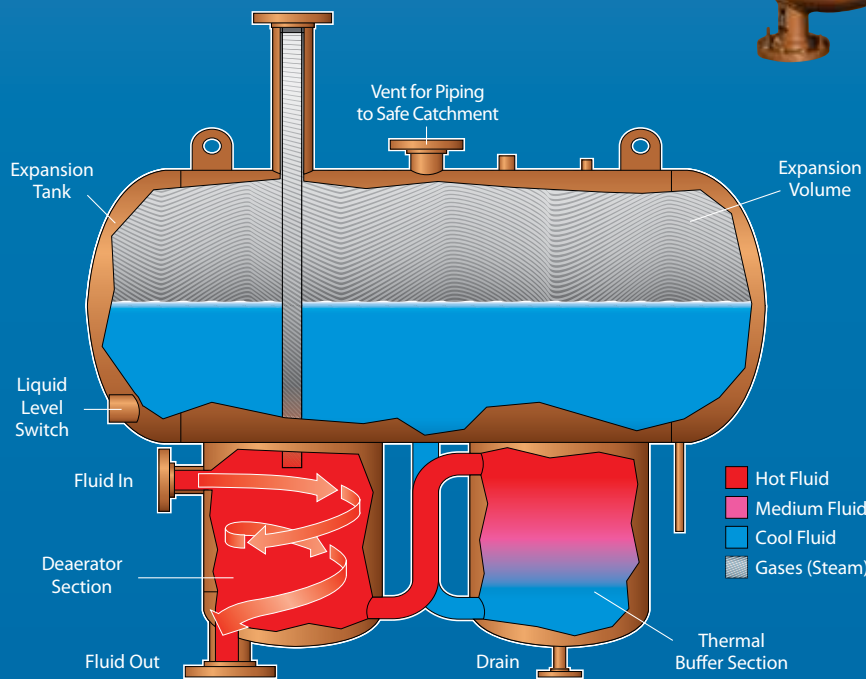

MODELS	FT-L	0200	0500	1000	1500	2000	3000	5000
Tank Sizing and Capacities								
Capacity	Gallons	52	132	264	397	528	793	1,310
	Liters	196	499	999	1,502	1,998	3,001	4,958
Initial Fill	Gallons	25	40	80	90	145	215	300
	Liters	94	151	302	340	548	813	1,135
Available for Expansion	Gallons	46	121	232	380	444	717	1,168
	Liters	174	458	878	1,438	1,680	2,714	4,421
Max System Volume	Gallons	184	525	1,000	1,400	1,700	2,600	4,600
	Liters	696	1,987	3,785	5,299	6,435	9,842	17,412
Dry Weight	LB	636	970	1,350	1,710	2,550	3,200	5,300
	KG	289	440	612	776	1,134	1,451	1,637

CUSTOM ENGINEERED SKIDDED SYSTEMS

Fulton's engineering and design capabilities are unmatched in the industry, providing comprehensive solutions to custom-designed thermal fluid systems. Our team of engineers and project managers assist in the specification and design of a "turnkey" system for each application. All engineered systems come with state-of-the-art operating controls and can have single-point electric, fuel supply, thermal fluid drain/fill, inlet/outlet, and any other applicable connection. From design to complete fabrication, trust Fulton and our many years of experience to build a system you can rely on for years to come.



The skid system shown here included one FT-0240-C heater, a circulating pump, expansion tank and a temperature control unit (TCU). This system was designed to provide thermal fluid and hot water to several dryers for a wastewater application.



This system includes two FT-0600-C thermal fluid heaters skid mounted with three circulating pumps (one pump acts as a backup for either heater), and one FT-5000-L expansion tank (not shown). These heaters are used to provide process heat for the manufacture of asphalt roofing shingles.

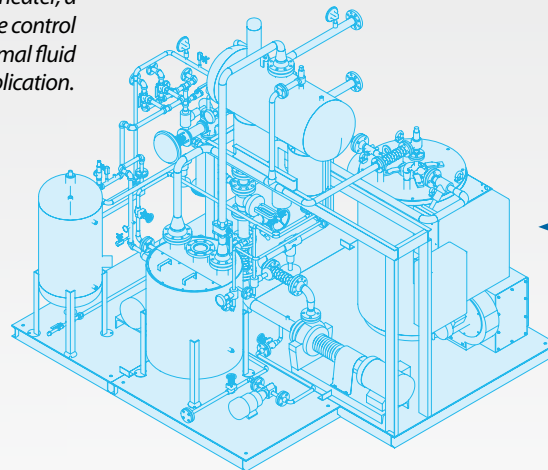

← Custom 3-D models are created for all engineered systems

 **Fulton**[®] The heat transfer innovators.

Fulton Thermal Corporation
972 Centerville Road, Pulaski, NY 13142
Call: (315) 298-5121 • Fax: (315) 298-6390



www.fulton.com

FTC-BRO_2013-1218