

# R.F. MacDonald Co.

SERVING YOU SINCE 1956

## LET R.F. MACDONALD CO. LASER ALIGN YOUR PUMPS AND EQUIPMENT.

### L A S E R   A L I G N M E N T

Laser Alignment is state-of-the-art technology.

Laser Alignment is available now for rotating equipment.

Laser Alignment can increase your mean time between pump seal failures by up to **300%**!

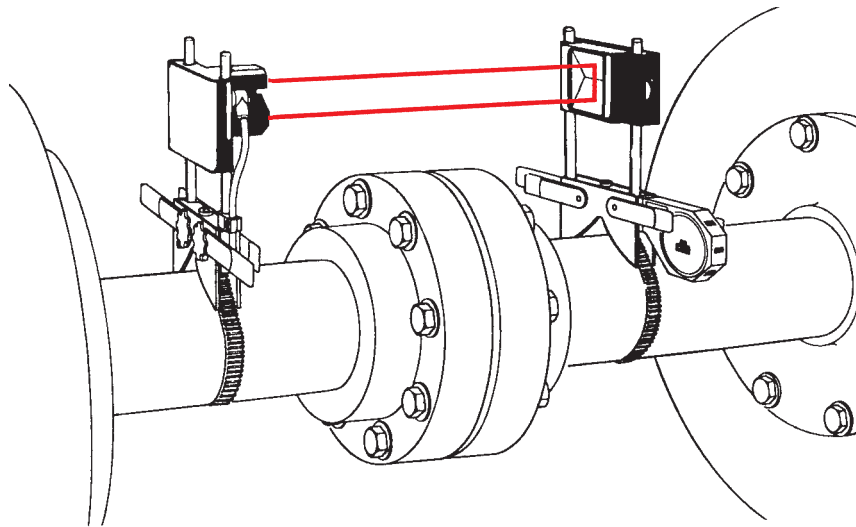

#### Why Take A Chance?

- 50% of all damage to rotating equipment is caused by misalignment.
- Dial indicator alignments are slow, complicated, frequently inaccurate.
- The risk of human error in dial indicator alignment is high.

#### R.F. MacDonald Co. Offers...

- Team of highly trained specialists.
- Class I, totally safe, industrial laser.
- Fully equipped service trucks in all locations to perform alignment and complete repairs.
- Provided with detailed computer generated records of all alignment procedures.

#### Fresno

4545 North Brawley Ave.  
Suite 103  
Fresno, CA 93722  
(559) 277-3496  
Fax: (559) 277-0577

#### Modesto

1549 Cummins Drive  
Modesto, CA 95358  
(209) 576-0726  
Fax: (209) 576-1312

#### Reno

1380 Greg Street  
Suite 222  
Sparks, Nevada 89431  
(702) 356-0300  
Fax: (702) 356-8955

#### San Francisco

25920 Eden Landing Road  
Hayward, CA 94545-3816  
(510) 784-0110  
Fax: (510) 784-1004

#### Las Vegas

4395 South Cameron  
Suite C  
Las Vegas, NV 89103  
(702) 220-6680  
Fax: (702) 220-6685

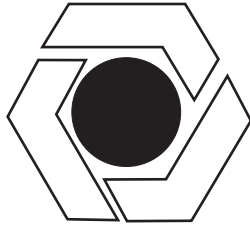

# R.F. MacDonald Co.

SERVING YOU SINCE 1956

## How Accurate are Dial Indicator Readings?

### Sum of All Errors



#### BRACKET SAG

- Not Measured.
- Inaccurately Measured.

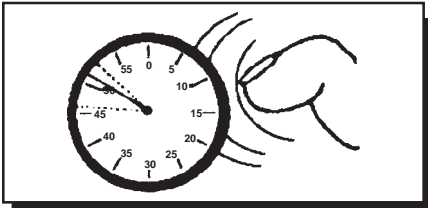

#### FRICITION / HYSTERESIS

- Internal Friction of Dial Indicators.
- Bracket Elasticity Absorbs Part of Deflection Forces.

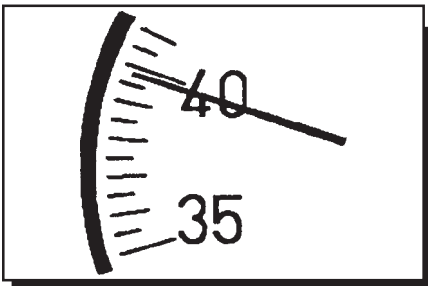

#### RESOLUTION 1 / 1000"

1/2 / 1000" error per reading can amount to a total error of several thousands inch in alignment calculation based upon 8 individual readings.

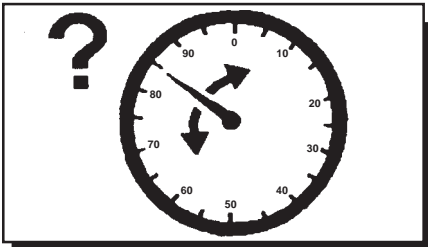

#### READING ERROR

- Sign Error  $\pm$  (+85 or -15?)
- Mirror Image.

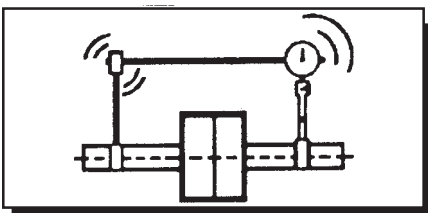

#### PLAY IN MECHANICAL COMPONENTS

- Looseness in Linkages.
- Aggravated by Vibration

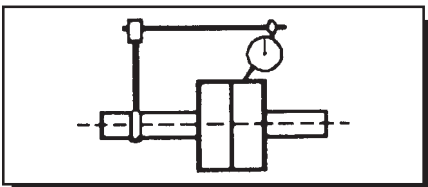

#### DIAL INDICATORS NOT MOUNTED PERPENDICULARLY.

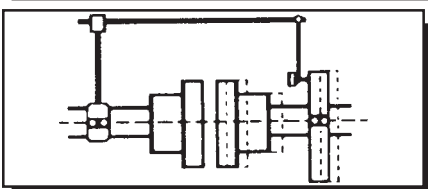

#### SHAFT ENDPLAY / FLOAT.