

# CBEX ELITE



1300-2200 HP

Boiler Book  
09/2017



## **CONTENTS**

FEATURES AND BENEFITS 3

PRODUCT OFFERING 3

DIMENSIONS AND RATINGS 4

CBEX Elite Steam Boiler Ratings 1300-2200 HP 5

CBEX Elite Steam Boiler Dimensions, 1300-1500 HP 6

CBEX Elite Steam Boiler Dimensions, 1600-2200 HP 7

PERFORMANCE DATA 8

ENGINEERING DATA 8

CBEX Elite Steam Boiler Safety Valve Outlet Size 11

CBEX Elite Steam Volume and Disengaging Area 11

CBEX Elite Blowdown Tank Sizing 12

CBEX Elite Recommended Steam Nozzle Size 12

Boiler Room Size 12

CBEX Elite Natural Gas Estimated Emission Levels 13

Altitude Correction for Gas 13

Predicted Fuel-to-Steam Efficiencies - Natural Gas 13

Gas Train (Siemens) 14

Gas Train (Maxon) 15

## **FEATURES AND BENEFITS**

The CBEX Elite firetube boiler is designed, manufactured, and packaged by Cleaver-Brooks. All units are factory fire tested and shipped as a package, ready for quick connection to utilities. In addition to the features provided on all Cleaver-Brooks Firetube boilers, the following features apply to the CBEX Elite.

### **Two Pass Design:**

- The packaged boiler offers high efficiency, flexibility, reliability, safety and ease of operation.

### **Front and Rear Access:**

- Davited front doors, all sizes.
- Provides access to front tube sheet and tubes.
- Large rear access plug for turnaround, tubes, and furnace access.

### **Natural Gas, No. 2 Oil, or Combination Burners Available:**

- Combination gas/oil burners provide quick fuel changeover without burner adjustment.

## **PRODUCT OFFERING**

Cleaver-Brooks CBEX Elite Boilers are available in 150-250 psig steam designs. Burners are available to fire natural gas, No. 2 oil, or a combination of oil and gas. Standard product offering is:

- 1300 - 2200 hp.
- Two pass wetback design.
- 150-250 psig steam (up to 1600 hp)  
150-200 psig steam (1800-2000 hp)  
150-190 psig steam (2200 hp)
- Full modulation, all sizes.

Available options include the following (contact your local Cleaver-Brooks authorized representative for option details).

- Boiler Options:
  - Additional screwed or flanged tappings.
  - Blowdown valves.
  - Non-return valves.
  - Feedwater valves and regulators.
  - Surface blowdown systems.
  - Surge load baffles.
  - Seismic design.
- Burner/Control Options:
  - Flame safeguard controllers.
  - Lead/lag system.
  - Special insurance and code requirements (e.g., FM, NFPA-85).
  - Alarm bell/silence switch.
  - Special motor requirements (TEFC, high efficiency).
  - Special indicating lights.

Main disconnect.  
Elapsed time meter.  
NEMA enclosures.  
Remote emergency shut-off (115V).  
Circuit breakers.  
Day/night controls.  
Special power requirements.  
Low NOx Equipment.

- Fuel Options:
  - Gas strainer.
  - Gas pressure gauge.
  - Future gas conversion.
  - Oversized/undersized gas trains.
  - Optional Oil Pumps.

### ***DIMENSIONS AND RATINGS***

Dimensions and ratings are shown in the following tables and illustrations. The information is subject to change without notice.

- Table 1. CBEX Elite Steam Boiler Ratings
- Figure 1. CBEX Elite Steam Boiler Dimensions 1300-1500 HP
- Figure 2. CBEX Elite Steam Boiler Dimensions 1600-2200 HP

**Table 1. CBEX Elite Steam Boiler Ratings 1300-2200 HP**

Boiler H.P.	1300	1400	1500	1600	1800	2000	2200	
<b>Ratings</b>								
Rated Capacity - Steam (lbs-steam/hr from & at 212°F)	44,850	48,300	51,750	55,200	62,100	69,000	75,900	
Output (1000 BTU/hr)	43,514	46,861	50,208	53,555	60,250	66,944	73,638	
Fireside Heating Surface (sq.ft.)	3528	4069	4212	4646	5382	5711	6640	
<b>Approximate Fuel Consumption At Rated Capacity</b>								
Light Oil Input (gph) - 150# Steam <sup>C</sup>	383.8	413.3	442.8	472.3	531.3	590.4	649.4	
Natural Gas Input (cfh) - 150# Steam <sup>A</sup>	53,725	57,858	61,991	66,123	74,389	82,654	90,920	
<b>Power Requirements - 60Hz, 3-Phase</b>								
Blower Motor Size (HP) <sup>B</sup>	Uncontrolled NOx	75	75	100	75	75	100	100
	30 ppm	75	100	125	100	100	100	125
	9 ppm	100	100	125	150	150	200	200
Oil Pump Motor HP (#2 Oil)	1.5	1.5	1.5	3	3	3	3	
Air Compressor Motor HP (#2 Oil)	15	15	15	Plant Air	Plant Air	Plant Air	Plant Air	
Notes: A. Input calculated at nominal 81% efficiency for 1000 BTU gas content B. For altitudes above 700 ft, contact local Cleaver Brooks authorized representative for verification of boiler and blower motor size. C. Input calculated at nominal 81% efficiency based on 140,000 BTU/gal								

**Figure 1. CBEX Elite Steam Boiler Dimensions, 1300-1500 HP**

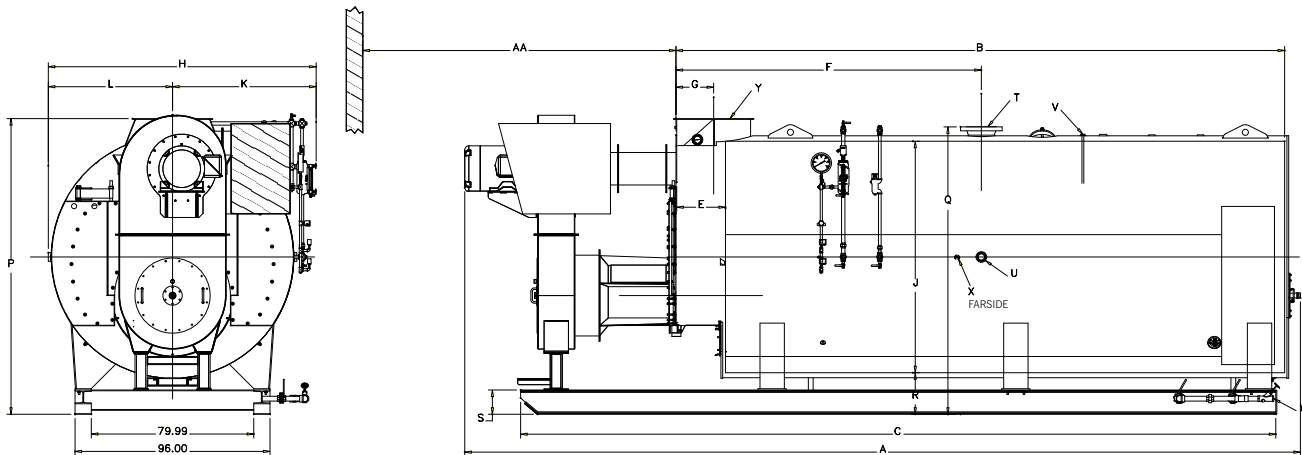

Boiler Horsepower	Dim.	1300	1400	1500
Lengths				
Overall	A	385	404	413
Shell	B	281	300	309
Base Frame	C	353	372	381
Over Tubesheets	D	256	275	384
Shell Extension	E	24	24	24
Front To Steam Nozzle	F	142	150	162
Front To Vent Outlet	G	18-1/2	18-1/2	18-1/2
Widths				
Overall	H	131	131	131
Boiler I.D.	J	114	114	114
Center To Water Column	K	71	71	71
Center To Lagging	L	60	60	60
Base Inside	M	80	80	80
Base Outside	N	96	96	96
Heights				
Base To Vent Outlet	P	145-1/2	145-1/2	145-1/2
Base To Steam Outlet	Q	141-1/2	141-1/2	141-1/2
Base To Boiler Bottom	R	20	20	20
Base Rail	S	12	12	12
Connection Sizes				
Steam Nozzle (150 PSIG)	T	10	12	12
Steam Nozzle (200 PSIG)	T			
Feed Water	U	3	3	3
Surface Blowoff	V	1	1	1
Blow Down	W	2	2	2
Chemical Feed	X	3/4	3/4	3/4
Vent Stack Outlet	Y	36	36	36
Minimum Clearances				
Tube Removal (Front Only)	AA	203	222	231
Weight In Lbs.				
Normal Water Capacity		41,320	43,829	45,392
Approx. Ship Weight (150 PSIG)		65,424	69,672	71,435
Approx. Ship Weight (200 PSIG)		72,087	76,810	78,799

**Figure 2. CBEX Elite Steam Boiler Dimensions, 1600-2200 HP**

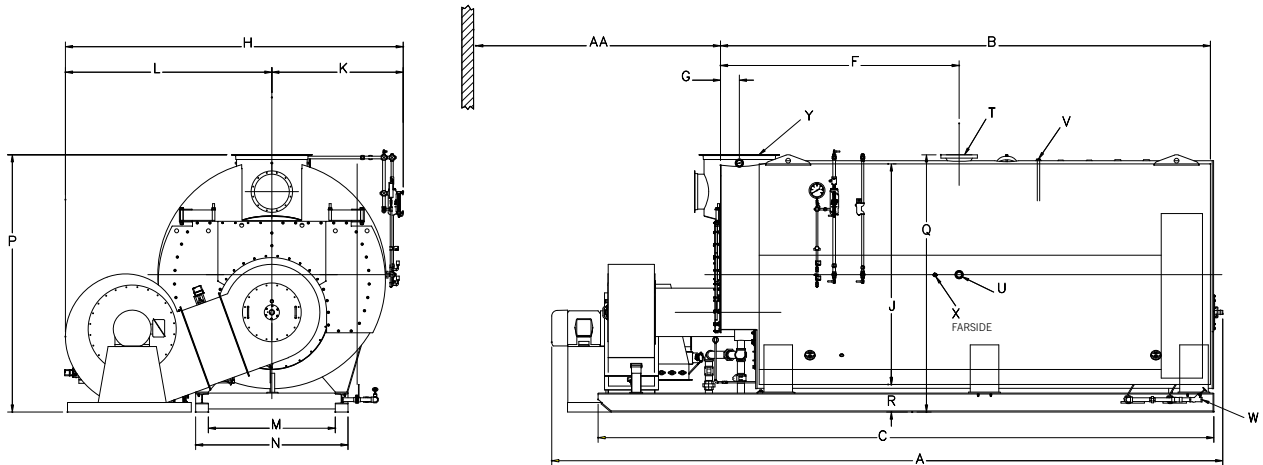

Boiler Horsepower	Dim.	1600	1800	2000	2200
Lengths					
Overall	A	410	424	410	424
Shell	B	296	310	296	310
Base Frame	C	374	388	374	388
Over Tubesheets	D	270	284	270	284
Shell Extension	E	24	24	24	24
Front To Steam Nozzle	F	142	150	142	150
Front To Vent Outlet	G	21-1/4	21-1/4	11-7/8	11-7/8
Widths					
Overall	H	207	207	213	213
Boiler I.D.	J	126	126	138	138
Center To Water Column	K	77	77	83	83
Center To Lagging	L	130	130	130	130
Base Inside	M	80	80	80	80
Base Outside	N	96	96	96	96
Heights					
Base To Vent Outlet	P	158	158	162	162
Base To Steam Outlet	Q	153-5/8	153-5/8	162	162
Base To Boiler Bottom	R	20	20	17-1/2	17-1/2
Base Rail	S	12	12	12	12
Connection Sizes					
Steam Nozzle (150 PSIG)	T	12	12	14	14
Steam Nozzle (200 PSIG)	T				
Feed Water	U	3	3	3	3
Surface Blowoff	V	1	1	1	1
Blow Down	W	2	2	2	2
Chemical Feed	X	3/4	3/4	3/4	3/4
Vent Stack Outlet	Y	42	42	44	44
Minimum Clearances					
Tube Removal (Front Only)	AA	216	230	216	230
Weight In Lbs.					
Normal Water Capacity		52,311	53,797	63,095	63,687
Approx. Ship Weight (150 PSIG)		78,667	83,445	92,706	99,133
Approx. Ship Weight (200 PSIG)		90,060	95,387	104,988	112,016

## **PERFORMANCE DATA**

### **Efficiency**

Table 9 shows predicted fuel-to-steam efficiencies (including radiation and convection losses) for Cleaver-Brooks CBEX Elite Firetube boilers. For specific efficiencies on firetube boiler offerings not listed here, contact your local Cleaver-Brooks authorized representative.

Cleaver-Brooks offers an industry leading fuel-to-steam boiler efficiency guarantee for CBEX Elite Firetube Boilers. The guarantee is based on the fuel-to-steam efficiencies shown in the efficiency tables and the following conditions. The efficiency percent number is only meaningful if the specific conditions of the efficiency calculations are clearly stated in the specification (see Cleaver-Brooks publication CB-7767 for a detailed description of efficiency calculations).

The boiler manufacturer shall guarantee that, at the time of startup, the boiler will achieve fuel-to-steam efficiency (as shown in the tables listed above) at 100% firing rate (add efficiency guarantees at 25%, 50%, and 75% of rating, if required). If the boiler(s) fail to achieve the corresponding guaranteed efficiency as published, the boiler manufacturer will rebate, to the ultimate boiler owner, five thousand dollars (\$5,000) for every full efficiency point (1.0%) that the actual efficiency is below the guaranteed level. The specified boiler efficiency is based on the following conditions.

1. Fuel specification used to determine boiler efficiency:

- Natural Gas

Carbon,% (wt) = 69.98

Hydrogen,% (wt) = 22.31

Sulfur,% (wt) = 0.0

Heating value, Btu/lb = 21,830

- No. 2 Oil

Carbon,% (wt) = 85.8

Hydrogen,% (wt) = 12.7

Sulfur,% (wt) = 0.2

Heating value, Btu/lb = 19,420

2. Efficiencies are based on ambient air temperature of 80 °F, relative humidity of 30%, and 15% excess air in the exhaust flue gas.

3. Efficiencies are based on the following radiation and convection losses. Firing rate of 25% - 1.2%, 50% - 0.6%, 75% - 0.4%, and 100% - 0.3%.

## **ENGINEERING DATA**

The following engineering information is provided for CBEX Elite Boilers. Additional detail is available from your local Cleaver-Brooks authorized representative.

### **Boiler Information**

Table 2 lists quantity and outlet size for safety valves supplied on CBEX Elite boilers.

Table 3 shows steam volume and disengaging area for CBEX Elite boilers.

Table 5 gives recommended steam nozzle sizes for CBEX Elite Boilers.

### **Blowdown Water Requirements**

Some local codes require blowdown tanks to be constructed in accordance with recommendations of



the National Board of Boiler and Pressure Vessel Inspectors.

The National Board's recommendations base the size of the blowdown tank on the removal of at least 4 inches of water from the boiler.

Table 4 lists the approximate quantity of water represented by 4 inches of water at normal operating level for Cleaver-Brooks CBEX Elite Boilers.

## **Burner/Control Information**

### ***Burner Characteristics***

Note that altitude correction and burner changes are required for higher altitudes which may alter dimensions, motor hp and gas pressures. Also 50 Hz applications and low NOx options should be reviewed by the Cleaver-Brooks authorized representative.

### ***Fuel Connections - Gas***

The local gas company should be consulted for requirements and authorization for installation and inspection of gas supply piping. Installation of gas supply piping and venting must be in accordance with all applicable engineering guidelines and regulatory codes. All connections made to the boiler should be arranged so that all components remain accessible for inspection, cleaning and maintenance.

A drip leg should be installed in the supply piping before the connection to the gas pressure regulator. The drip leg should be at least as large as the inlet fitting supplied with the boiler. Consideration must be given to both volume and pressure requirements when choosing gas supply piping size. Refer to the boiler dimension diagram provided by Cleaver-Brooks for the particular installation. Connections to the burner gas train should be made with a union, so that gas train components or the burner may be easily disconnected for inspection or service. Upon completion of the gas piping installation, the system should be checked for gas leakage and tight shutoff of all valves.

### ***Fuel Connections - Oil***

Oil-fired burners are equipped with an oil pump, which draws fuel from a storage tank and supplies pressurized oil to the burner nozzle(s). The burner supply oil pump has a greater capacity than the burner requires for the maximum firing rate. Fuel not delivered to the nozzle is returned to the storage tank. A two-pipe (supply and return) oil system is recommended for all installations. Oil lines must be sized for the burner and burner supply oil pump capacities.

The burner supply oil pump suction should not exceed 10" Hg. If a transfer pump is used, it must have a pumping capacity at least equal to that of the burner pump(s). Supply pressure to the burner pump should not exceed 3 psig.

A strainer must be installed in the supply piping upstream of the burner supply pump in order to prevent entry of foreign material into the pump, fuel control valves, or burner nozzle(s). The strainer must be sized for the burner supply pump capacity. A strainer mesh of 150 microns (0.005") is recommended.

Install a check valve in the line to prevent draining of the oil suction line when the burner is not in operation. Location of the check valve varies with the system, but usually it is located as close as possible to the storage tank.

Installation of a vacuum gauge in the burner supply line between the burner oil pump and the strainer is recommended. Regular observation and recording of the gauge indication will assist in determining when the strainer needs servicing.

Upon completion of the oil piping installation, the system should be checked for oil or air leakage and

tight shutoff of all valves.

### **Boiler Room Information**

Table 6 shows typical boiler room length and width requirements.

### **Stack Support Capabilities**

CBEX Elite boilers can support up to 2000 lbs. without additional support.

CBEX Elite boilers can be reinforced to support up to 3000 lbs.

### **Boiler Room Combustion Air**

When determining boiler room air requirements, the size of the room, air flow, and velocity of air must be reviewed as follows:

1. Size (area) and location of air supply openings in boiler room.
  - A. Two (2) permanent air supply openings in the outer walls of the boiler room are recommended. Locate one (1) at each end of the boiler room, preferably below a height of 7 feet. This allows air to sweep the length of the boiler.
  - B. Air supply openings can be louvered for weather protection, but they should not be covered with fine mesh wire, as this type of covering has poor air flow qualities and is subject to clogging by dust or dirt.
  - C. A vent fan in the boiler room is not recommended, as it could create a slight vacuum under certain conditions and cause variations in the quantity of combustion air. This can result in unsatisfactory burner performance.
  - D. Under no condition should the total area of the air supply openings be less than one (1) square foot.
  - E. Size the openings by using the formula:

$$\text{Area (sq-ft)} = \text{CFM/FPM}$$

2. Amount of air required (cfm).
  - A. Combustion Air = Rated bhp x 8 cfm/bhp.
  - B. Ventilation Air = Maximum bhp x 2 cfm/bhp or a total of 10 cfm/bhp - up to 1000 feet elevation. Add 3 percent more per 1000 feet of added elevation.
3. Acceptable air velocity in Boiler Room (fpm).
  - A. From floor to (7) foot height - 250 fpm.
  - B. Above (7) foot height - 500 fpm.

Example: Determine the area of the boiler room air supply openings for (1) 1000 hp boiler at 800 feet altitude. The air openings are to be 5 feet above floor level.

- Air required:  $1000 \times 10 = 10000$  cfm (from 2B above).
- Air velocity: Up to 7 feet = 250 fpm (from 3 above).
- Area Required:  $\text{Area} = \text{cfm/fpm} = 10000/250 = 40$  Sq-ft total.
- Area/Opening:  $40/2 = 20$  sq-ft/opening (2 required).

***Consult local codes, which may supersede these requirements.***

### **Stack/Breeching Size Criteria**

The design of the stack and breeching must provide the required draft at each boiler flue gas outlet. Proper draft is critical to burner performance.

Although constant pressure at the flue gas outlet of the CBEX Elite is not required, it is necessary to size the stack/breeching to limit flue gas pressure variation. The allowable pressure range is  $-0.50''$

W.C. to +0.50" W.C. The maximum pressure variation at any firing rate for the boiler is 0.50" W.C. The low NOx option allowable pressure range is -0.25" W.C. to +0.25" W.C. The maximum pressure variation at any firing rate for the boiler is 0.25"W.C.

Stack and breeching sizes should always be provided by a reputable stack supplier who will design the stack and breeching system based on the above criteria. Your local Cleaver-Brooks authorized representative is capable of assisting in your evaluation of the stack/breeching design.

**Table 2. CBEX Elite Steam Boiler Safety Valve Outlet Size**

BOILER HP	VALVE SETTING		VALVE SETTING		VALVE SETTING	
	150 PSIG STEAM		200 PSIG STEAM		250 PSIG STEAM	
	NO. OF VALVES REQ'D	OUTLET SIZE (IN.)	NO. OF VALVES REQ'D	OUTLET SIZE (IN.)	NO. OF VALVES REQ'D	OUTLET SIZE (IN.)
1300	2	(2) @ 4	2	(1) @ 4 (1) @ 3	2	(2) @ 3
1400	3	(2) @ 3 (1) @ 4	2	(1) @ 4 (1) @ 3	2	(2) @ 3
1500	3	(1) @ 4 (2) @ 3	2	(2) @ 4	2	(1) @ 4 (1) @ 3
1600	2	(2) @ 4	2	(2) @ 4	2	(1) @ 4 (1) @ 3
1800	3	(2) @ 4 (1) @ 3	2	(2) @ 4	2	(1) @ 4 (1) @ 3
2000	3	(3) @ 4	2	(2) @ 4	2	(2) @ 4
2200	3	(2) @ 4 (1) @ 3	2	(2) @ 4	2	(2) @ 4

NOTE: Valve manufacturers are Kunkle, Consolidated or Conbraco, depending on availability.

**Table 3. CBEX Elite Steam Volume and Disengaging Area**

BOILER HP	STEAM VOLUME CU-FT	STEAM RELIEVING AREA SQ-IN
1300	211.3	161.3
1400	226.9	173.3
1500	234.4	179
1600	290.1	191.2
1800	305.1	201.1
2000	339.7	208.1
2200	375.6	221.8

NOTES:

1. Based on normal water level.
2. Based on 150 psig design pressure.

**Table 4. CBEX Elite Blowdown Tank Sizing**

BOILER HP	WATER (GAL)
1300	203
1400	218
1500	225
1600	241
1800	253
2000	265
2200	279

NOTE: Quantity of water removed from boiler by lowering normal water line 2".

**Table 5. CBEX Elite Recommended Steam Nozzle Size**

OPERATING PRESSURE PSIG	BOILER HP						
	1300	1400	1500	1600	1800	2000	2200
50	14	16	16	16	16	18	18
75	12	14	14	14	14	16	16
100	12	12	12	12	14	14	14
125	10	10	12	12	12	12	14
150	10	10	10	10	12	12	12
200	8	10	10	10	10	10	10
225	8	8	8	10	10	10	10

## NOTES:

1. Steam nozzle sizes given in inches.
2. Recommended steam nozzle sizes based on 5000 fpm max. steam velocity.

**Table 6. Boiler Room Size**

BOILER HP	1300	1400	1500	1600	1800	2000	2200
LENGTH (Inches) <sup>1</sup>	624	662	680	662	690	662	690
WIDTH (Inches) <sup>2</sup>	218	218	218	226	226	234	234

## NOTES:

1. Recommended Minimum Distance Between Boiler and Wall. Length dimension allows for a clear 36" aisle between the boiler rear and the wall. This dimension also includes a tube replacement allowance (front only).
2. Recommended Minimum Width Dimension. Width dimension allows for a clear aisle of 36". If space permits, this aisle dimension should be increased.

**Table 7. CBEX Elite Natural Gas Estimated Emission Levels**

POLLUTANT	UNITS	
CO	ppm*	100
	lb/MMBtu	0.073
NO <sub>x</sub>	ppm*	100
	lb/MMBtu	0.117
SO <sub>x</sub>	ppm*	1
	lb/MMBtu	0.002
HC/VOC <sub>5</sub>	ppm*	14
	lb/MMBtu	0.006
PM	ppm*	-
	lb/MMBtu	0.01

\* ppm levels are given on a dry volume basis and corrected to 3% oxygen (15% excess air)

**Table 8. Altitude Correction for Gas**

ALTITUDE (FT)	CORRECTION FACTOR	ALTITUDE (FT)	CORRECTION FACTOR
1000	1.04	6000	1.25
2000	1.07	7000	1.3
3000	1.11	8000	1.35
4000	1.16	9000	1.4
5000	1.21	-	-

To obtain minimum required gas pressure at altitudes above 700 feet, multiply the pressure by the listed factors:

Inches WC x 0.577 = oz/sq-in.

oz/sq-in x 1.732 = inches WC.

Inches WC x 0.0361 = psig.

oz/sq-in x 0.0625 = psig.

psig x 27.71 = Inches WC.

psig x 16.0 = oz/sq-in.

**Table 9. Predicted Fuel-to-Steam Efficiencies - Natural Gas**

BHP	OPERATING PRESSURE = 125 psig			
	% OF LOAD			
	25%	50%	75%	100%
1300	81.8	82.3	82.2	82.0
1400	81.8	82.4	82.3	82.2
1500	81.4	81.6	81.1	80.6
1600	81.6	81.9	81.6	81.3
1800	81.6	81.9	81.6	81.3
2000	81.6	81.9	81.6	81.3
2200	81.6	81.9	81.6	81.3

**Table 10. Gas Train (Siemens)**

Boiler HP	Uncontrolled NOx		30 ppm		9 ppm	
	Gas Train Size, in	Pressure Range PSI	Gas Train Size, in	Pressure Range PSI	Gas Train Size, in	Pressure Range PSI
1300	3 - 4	8.0 - 10.	3 - 4	9.2 - 10	3 - 4	8.3 - 10
	4	5.1 - 8.0	4	6.2 - 9.2	4	5.4 - 8.3
1400	3 - 4	9.5 - 10			3 - 4	9.7 - 10
	4	5.9 - 9.5	4	7.3 - 10	4	6.2 - 9.7
1500	4	6.8 - 10	4	8.4 - 10	4	7.1 - 10
	6	4.9 - 6.8	6	6.6 - 10	6	5.3 - 7.1

Notes: Table is based on Siemens gas train , which includes a regulating actuator.

Pressures are based on a boiler nominal efficiency of 81%.

Incoming pressure is not to exceed 10 psi

<b>UNDERSIZE</b>
<b>STANDARD</b>
<b>OVERSIZE</b>

**Table 11. Gas Train (Maxon)**

Boiler HP	Gas Flow SCFH	WITH 3" FISHER 1098EGR REGULATOR & 4" MAXON GAS TRAIN					
		Uncontrolled		30 ppm		9 ppm	
		Regulated Pressure (psi)	Supply Pressure (psi)	Regulated Pressure (psi)	Supply Pressure (psi)	Regulated Pressure (psi)	Supply Pressure (psi)
1600	66,950	7.2	10.5 - 15	7.2	10.5 - 15	6.1	9.5 - 15
1800	75,319	10.4	14.5 - 20	10.4	14.5 - 20	6.6	11 - 15
2000	83,688	11.2	16.5 - 20	11.2	16.5 - 20	7.1	12.5 - 15
2200	92,056	13.4	18.5 - 20	13.4	18.5 - 20	7.1	13.5 - 15

Boiler HP	Gas Flow SCFH	WITH 4" FISHER 1098EGR REGULATOR & 4" MAXON GAS TRAIN					
		Uncontrolled		30 ppm		9 ppm	
		Regulated Pressure (psi)	Supply Pressure (psi)	Regulated Pressure (psi)	Supply Pressure (psi)	Regulated Pressure (psi)	Supply Pressure (psi)
1600	66,950	6.9	9 - 15	6.9	9 - 15	5.8	8 - 15
1800	75,319	10.0	12 - 20	10.0	12 - 20	6.2	8 - 15
2000	83,688	10.7	12.5 - 20	10.7	12.5 - 20	6.6	8.5 - 15
2200	92,056	12.8	15.5 - 20	12.8	15.5 - 20	6.5	9.5 - 15

Boiler HP	Gas Flow SCFH	WITH 4" FISHER 1098EGR REGULATOR & 6" MAXON GAS TRAIN					
		Uncontrolled		30 ppm		9 ppm	
		Regulated Pressure (psi)	Supply Pressure (psi)	Regulated Pressure (psi)	Supply Pressure (psi)	Regulated Pressure (psi)	Supply Pressure (psi)
1600	66,950	5.8	8 - 15	5.8	8 - 15	4.7	6.5 - 15
1800	75,319	8.6	10.5 - 15	8.6	10.5 - 15	4.8	7 - 15
2000	83,688	8.9	11 - 20	8.9	11 - 20	4.9	7.5 - 15
2200	92,056	10.7	13.5 - 20	10.7	13.5 - 20	4.4	7.5 - 15

Notes: Table is based on Maxon gas train, which includes a Fisher 1098EGR regulator.  
Pressures are based on a boiler nominal efficiency of 81%.

**UNDERSIZE**  
**STANDARD**  
**OVERSIZE**

