

# Model CBL 800-1600 HP



## TABLE OF CONTENTS

FEATURES AND BENEFITS . . . . .	3
Three Pass or Four Pass Design: . . . . .	3
Front and Rear Doors: . . . . .	3
Natural Gas, No. 2 Oil, No. 6 Oil, or Combination Burners Available: . . . . .	3
PRODUCT OFFERING . . . . .	3
DIMENSIONS AND RATINGS . . . . .	4
PERFORMANCE DATA . . . . .	9
Efficiency . . . . .	9
ENGINEERING DATA . . . . .	10
Boiler Information . . . . .	10
Burner/Control Information . . . . .	10
Burner Characteristics . . . . .	10
Gas-Fired Burners . . . . .	11
Fuel Connections - Gas . . . . .	11
Fuel Connections - Oil . . . . .	11
Boiler Room Information . . . . .	12
Stack Support Capabilities . . . . .	12
Boiler Room Combustion Air . . . . .	12
Stack/Breeching Size Criteria . . . . .	12
SAMPLE SPECIFICATIONS . . . . .	21

ILLUSTRATIONS

Figure A5-1. CBL Steam Boiler Dimensions, 4 Pass (Page 1 of 2) (4 pass) . . . . .7  
 Figure A5-2. Space Required to Open Rear Doors on CBL Boilers . . . . .9  
 Figure A5-3. CBL Boilers Lifting Lug Location . . . . .9  
 Figure A5-4. CBL Boiler Mounting Piers . . . . .10  
 Figure A5-5. No. 2 Oil Piping, Single Boiler Installation, Oil Pump Integral With Boiler . . . . .19  
 Figure A5-6. No. 6 Oil Piping, Single Boiler Installation, Remote Oil Pumps . . . . .19  
 Figure A5-7. Boiler Room Length (Typical Layout) . . . . .19  
 Figure A5-8. Boiler Room Width (Typical Layouts) . . . . .20

TABLES

Table A5-1. CBL Steam Boiler Ratings . . . . .5  
 Table A5-2. CBL Input Ratings (3-Pass Boilers) . . . . .5  
 Table A5-3. CBL Input Ratings (4-Pass Boilers) . . . . .6  
 Table A5-4. Predicted Fuel-to-Steam Efficiencies (%) CBL Boilers- 125 psig,  
 Natural Gas, 5sq. ft./BHP, 4 Pass . . . . .14  
 Table A5-5. Predicted Fuel-to-Steam Efficiencies (%) CBL Boilers- 125 psig,  
 No. 2 Oil, 5sq. ft./BHP, 4 Pass . . . . .14  
 Table A5-6. Predicted Fuel-to-Steam Efficiencies (%) CBL Boilers- 125 psig,  
 No. 6 Oil, 5sq. ft./BHP, 4 Pass . . . . .14  
 Table A5-7. Predicted Fuel-to-Steam Efficiencies (%) CBL Boilers- 125 psig,  
 Natural Gas, 4 sq. ft./BHP, 3 Pass . . . . .15  
 Table A5-8. Predicted Fuel-to-Steam Efficiencies (%) CBL Boilers- 125 psig,  
 No. 2 Oil, 4 sq. ft./BHP, 3 Pass . . . . .15  
 Table A5-9. Predicted Fuel-to-Steam Efficiencies (%) CBL Boilers- 125 psig,  
 No. 6 Oil, 4 sq. ft./BHP, 3 Pass . . . . .15  
 Table A5-10. CBL Steam Boiler Safety Valve Outlet Size . . . . .16  
 Table A5-11. CBL Recommended Steam Nozzle Size . . . . .16  
 Table A5-12. CBL Steam Volume and Disengaging Areas . . . . .17  
 Table A5-13. CBL Recommended Non-Return Valve Size . . . . .17  
 Table A5-14. CBL Blowdown Tank Sizing Information . . . . .17  
 Table A5-15. CBL gas train connection size and gas pressure requirements. . . . .18  
 Table A5-16. Altitude Correction for Gas . . . . .18

## FEATURES AND BENEFITS

The CBL 800-1600 HP Firetube boiler is designed, manufactured, and packaged by Cleaver-Brooks. All units are factory fire tested and shipped as a package, ready for quick connection to utilities. In addition to the features provided on all Cleaver-Brooks Firetube boilers, the following features apply to the CBL.

### *Three Pass or Four Pass Design:*

- The packaged boiler offers high efficiency, flexibility, reliability, safety and ease of operation.

### *Front and Rear Doors:*

- Davited, front and rear doors, all sizes.
- Provides access to front tube sheet and furnace.
- Large rear access plug for turnaround and furnace access.
- Rear door completely covers and insulates rear tube sheet.

### *Natural Gas, No. 2 Oil, No. 6 Oil, or Combination Burners Available:*

- Combination gas/oil burners provide quick fuel changeover without burner adjustment.

## PRODUCT OFFERING

Cleaver-Brooks CBL Boilers are available in low pressure and high pressure steam and hot water designs. Burners are available to fire natural gas, No. 2 oil, No. 6 oil, or a combination of oil and gas. Standard product offering is:

- 800 - 1600 hp.
- Three pass wetback design or four pass wetback design.
- 4 or 5 square foot of heating surface per boiler horsepower
- 15- 250 psig steam in most sizes.
- 30 & 125 psig hot water in most sizes.
- Full modulation, all sizes.

Available options include the following (contact your local Cleaver-Brooks authorized representative for option details).

- Boiler Options:
  - Additional screwed or flanged tappings.
  - Blowdown valves.
  - Non-return valves.
  - Feedwater valves and regulators.
  - Surface blowdown systems.
  - Surge load baffles.
  - Seismic design.
- Burner/Control Options:
  - Flame safeguard controllers.
  - Lead/lag system.

- Special insurance and code requirements (e.g., IRI, FM, NFPA8501).
- Alarm bell/silence switch.
- Special motor requirements (TEFC, high efficiency).
- Special indicating lights.
- Main disconnect.
- Elapsed time meter.
- NEMA enclosures.
- Remote emergency shut-off (115V).
- Circuit breakers.
- Day/night controls.
- Special power requirements.
- Low NOx Equipment.
- HAWK ICS
- Fuel Options:
  - Gas strainer.
  - Gas pressure gauge.
  - Future gas conversion.
  - Oversized/undersized gas trains.
  - Optional Oil Pumps.

## ***DIMENSIONS AND RATINGS***

Dimensions and ratings for the CBL Boilers are shown in the following tables and illustrations. The information is subject to change without notice.

- Table A5-1. CBL Steam Boiler Ratings
- Table A5-2. Heating Surface
- Figure A5-1. CBL Steam Boiler Dimensions
- Figure A5-2. CBL Boiler Space Requirements to Open Rear Door
- Figure A5-3. Lifting Lug Location, CBL Boilers
- Figure A5-4. CBL Boiler Mounting Piers

**Table A5-1. CBL Steam Boiler Ratings**

BOILER HP		800	900	1000	1100	1200	1300	1400	1500	1600
RATINGS - SEA LEVEL TO 1000 FT <sup>B</sup>										
Rated Capacity (lbs-steam/hr from and at 212 °F)		27600	31050	34500	37950	41400	44850	48300	51750	55200
Btu Output (1000 Btu/hr)		26780	30128	33475	36823	40170	43518	46865	50213	53560
POWER REQUIREMENTS — SEA LEVEL TO 1000 FT ( 60 HZ)										
Blower Motor hp <sup>A</sup> 4 sq ft/BHP	3 pass	-	-	75	60	75	75	75	100	Contact Factory
	4 pass	-	-	60	75	75	75	100	100	
Blower Motor hp <sup>A</sup> 5 sq ft/BHP	3 pass	60	75	75	60	75	75	75	100	
	4 pass	75	75	60	60	75	75	75	100	
Oil Pump Motor hp (#2 oil)		1	1-1/2	1-1/2	1-1/2	1-1/2	1-1/2	1-1/2	1-1/2	
Oil Pump Motor hp (#6 oil)		1	1	1	1	1	1	1	1-1/2	
Air Comp. Motor, hp (#2 oil)		7-1/2	15	15	15	15	15	15	15	
Oil heater Kw (#6 oil)		10	10	10	15	15	15	15	15	
NOTES: A. Blower motor HP may increase if a low NOx option is added B. Ratings based on nominal 80% efficiency. C. Ratings based on 60 hertz, please verify 50 hertz ratings with factory.										

**Table A5-2. CBL Input Ratings (3-Pass Boilers)**

Boiler Square Foot Heating Surface	4000	4500	5000	5500	6000	6500	7000	7500
Approximate Fuel Consumption <sup>D</sup>								
Horsepower (5 sq.ft./bhp)	800	900	1000	1100	1200	1300	1400	1500
Natural Gas <sup>A</sup> (cfh)	33475	37659	41844	46028	50213	54397	58581	62766
No. 2 Oil <sup>B</sup> (gph)	239.1	269.0	298.9	328.8	358.7	388.5	418.4	448.3
No. 6 Oil <sup>C</sup> (gph)	223.2	251.1	279.0	306.9	334.8	362.6	390.5	418.4
Horsepower (4 sq.ft./bhp)	1000	1100	1200	1300	1500	1600		
Natural Gas <sup>A</sup> (cfh)	41844	46028	50213	54397	62766	66950		
No. 2 Oil <sup>B</sup> (gph)	298.9	328.8	358.7	388.5	448.3	478.2		
No. 6 Oil <sup>C</sup> (gph)	279.0	306.9	334.8	362.6	418.4	446.3		

Notes:  
A. Natural gas based on heating value of 1000 BTU/cu.ft  
B. No. 2 oil based on heating value of 140,000 BTU/gal.  
C. No. 6 oil based on heating value of 150,000 BTU/gal.  
D. Ratings based on nominal 80% efficiency.

**Table A5-3. CBL Input Ratings (4-Pass Boilers)**

Boiler Square Foot Heating Surface	4000	4500	5000	5500	6000	6500	7000	7500
Approximate Fuel Consumption <sup>D</sup>								
Horsepower (5 sq.ft./bhp)	800	900	1000	1100	1200	1300	1400	1500
Natural Gas <sup>A</sup> (cfh)	32659	36741	40823	44905	48988	53070	57152	61235
No. 2 Oil <sup>B</sup> (gph)	233.3	262.4	291.6	320.8	349.9	379.1	408.2	437.4
No. 6 Oil <sup>C</sup> (gph)	217.7	244.9	272.2	299.4	326.6	353.8	381.0	408.2
Horsepower (4 sq.ft./bhp)	1000	1100	1200	1300	1500	1600		
Natural Gas <sup>A</sup> (cfh)	40823	44905	48988	53070	61235	65317		
No. 2 Oil <sup>B</sup> (gph)	291.6	320.8	349.9	379.1	437.4	466.6		
No. 6 Oil <sup>C</sup> (gph)	272.2	299.4	326.6	353.8	408.2	435.4		

Notes:

A. Natural gas based on heating value of 1000 BTU/cu.ft

B. No. 2 oil based on heating value of 140,000 BTU/gal.

C. No. 6 oil based on heating value of 150,000 BTU/gal.

D. Ratings based on nominal 82% efficiency.

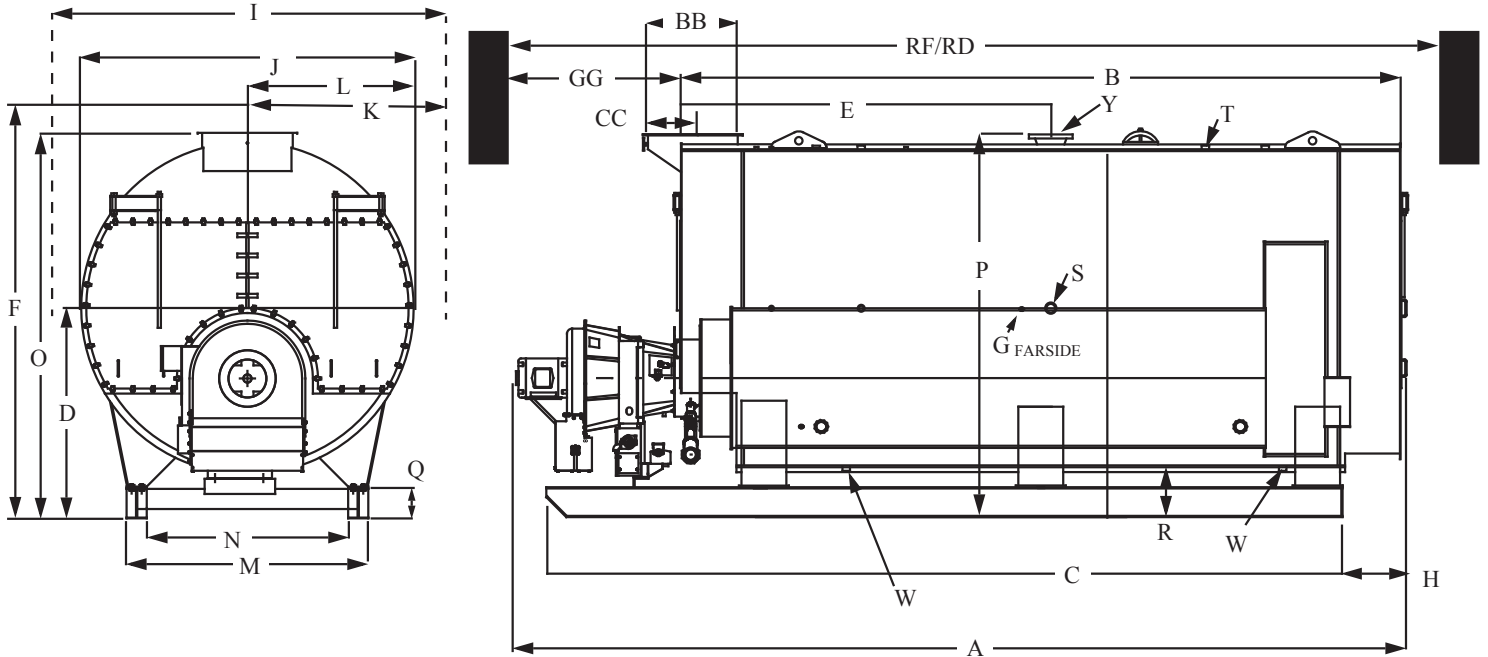

BOILER SQUARE FOOT HEATING SURFACE	DIM	4000	4500	5000	5500	6000	6500	7000	7500
Boiler Horsepower@ 5 ft <sup>2</sup> /bhp		800	900	1000	1100	1200	1300	1400	1500
Boiler Horsepower @ 4 ft <sup>2</sup> /bhp		1000	1100	1200	1300	1500	1600	-	-
LENGTHS									
Overall *B	A	367	394	386	411	434	387	406	425
Shell	B	293	323	288	312	335	304	323	342
Base Frame *	C	285	317	282	304	327	296	315	334
Base Frame to Rear Flange	H	26	26	26	26	26	26	26	26
Flange to Steam Nozzle	E	148	148	148	148	148	148	148	148
WIDTHS									
Overall With Trim	I	144	144	156	156	156	168	168	168
I. D. Boiler	J	114	114	126	126	126	138	138	138
Center to Water Column	K	72	72	78	78	78	84	84	84
Center to Lagging	L	59-1/2	59-1/2	65-3/4	65-3/4	65-3/4	71 3/4	71 3/4	71 3/4
Base Outside	M	96	96	96	96	96	96	96	96
Base Inside	N	80	80	80	80	80	80	80	80
* Approximate - varies with burner selection									
Boiler Horsepower@ 5 ft <sup>2</sup> /bhp		800	900	1000	1100	1200	1300	1400	1500
Boiler Horsepower @ 4 ft <sup>2</sup> /bhp		1000	1100	1200	1300	1500	1600	-	-

Figure A5-1. CBL Steam Boiler Dimensions, 4 Pass (Page 1 of 2)

BOILER SQUARE FOOT HEATING SURFACE	DIM	4000	4500	5000	5500	6000	6500	7000	7500
HEIGHTS									
Base to piping connections	F	149	149	161	161	161	168-1/8	168-1/8	168-1/8
Base to Boiler Centerline	D	77-1/2	77-1/2	83-3/4	83-3/4	83-3/4	86-1/2	86-1/2	86-1/2
Base to Vent Outlet	O	141	141	153-1/2	153-1/2	153-1/2	162-1/8	162-1/8	162-1/8
Base to Steam Outlet	P	141	141	153-1/2	153-1/2	153-1/2	162-1/8	162-1/8	162-1/8
Base Frame	Q	12	12	12	12	12	12	12	12
Base to Bottom Boiler	R	20	20	20	20	20	17	17	17
CONNECTIONS									
Chemical Feed	G	3/4	3/4	3/4	3/4	3/4	3/4	3/4	3/4
Feedwater Inlet (Both Sides)	S	3	3	3	3	3	3	3	3
Steam Nozzle <sup>A</sup> (150 psig)	Y	10	10	10	12	12	12	12	12
Blowdown - Front & Rear	W	2	2	2	2	2	2	2	2
Surface Blowoff	T	1	1	1	1	1	1	1	1
Vent Stack Diameter (Flanged)	BB	32	32	36	36	36	42	42	42
Flange to Center Vent	CC	17-1/2	17-1/2	19-1/2	19-1/2	19-1/2	24	24	24
MISCELLANEOUS									
Rear Door Swing <sup>c</sup>	AA	-	-	-	-	-	-	-	-
Tube Removal - Front Only	GG	246	276	217	241	264	233	252	271
Min. Boiler Room Length For Tube Removal Front	RF	537	597	538	586	632	665	703	741
Min. Boiler Room Length For Tube Removal Thru Door	RD	484	514	489	513	536	528	547	566
Normal Water Weight (Lbs)		43800	49400	49300	54000	60000	61000	66000	71000
Flooded Water Weight (Lbs)		54500	61300	65300	71900	78300	83000	89000	96000
Approx. Shipping Wt. 15/30 psig (Lbs.)		58000	63000	73100	77200	82200	87000	91700	96600
Approx. Shipping Wt. 150 psig (Lbs.)		65000	71000	79600	85300	90900	97300	102600	108200
Approx. Shipping Wt. 200 psig (Lbs.)		73500	82200	88600	95000	101500	107800	115500	121000
Approx. Shipping Wt. 250 psig (Lbs.)		81300	89000	97200	104000	110000	118000	124000	132000
NOTES: Accompanying dimensions, while sufficiently accurate for layout purposes, must be confirmed for actual option requirements. A. 300 psig Flange. See recommended steam nozzle size chart for operating pressure greater than 125 psig. B. Add 11 1/2 inches to dimension "B" for a three pass boiler. C. Reference Figure A11-2.									

Figure A5-1. CBL Steam Boiler Dimensions, 4 Pass (Page 2 of 2)



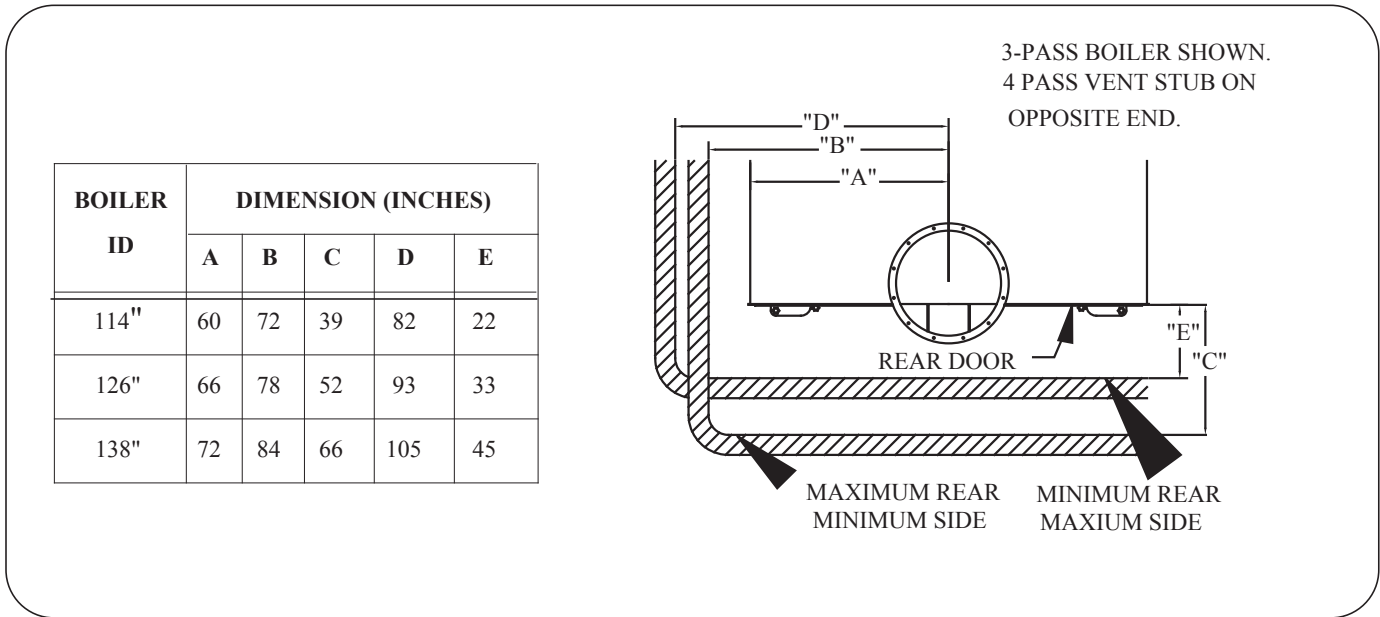

Figure A5-2. Space Required to Open Rear Doors on CBL Boilers

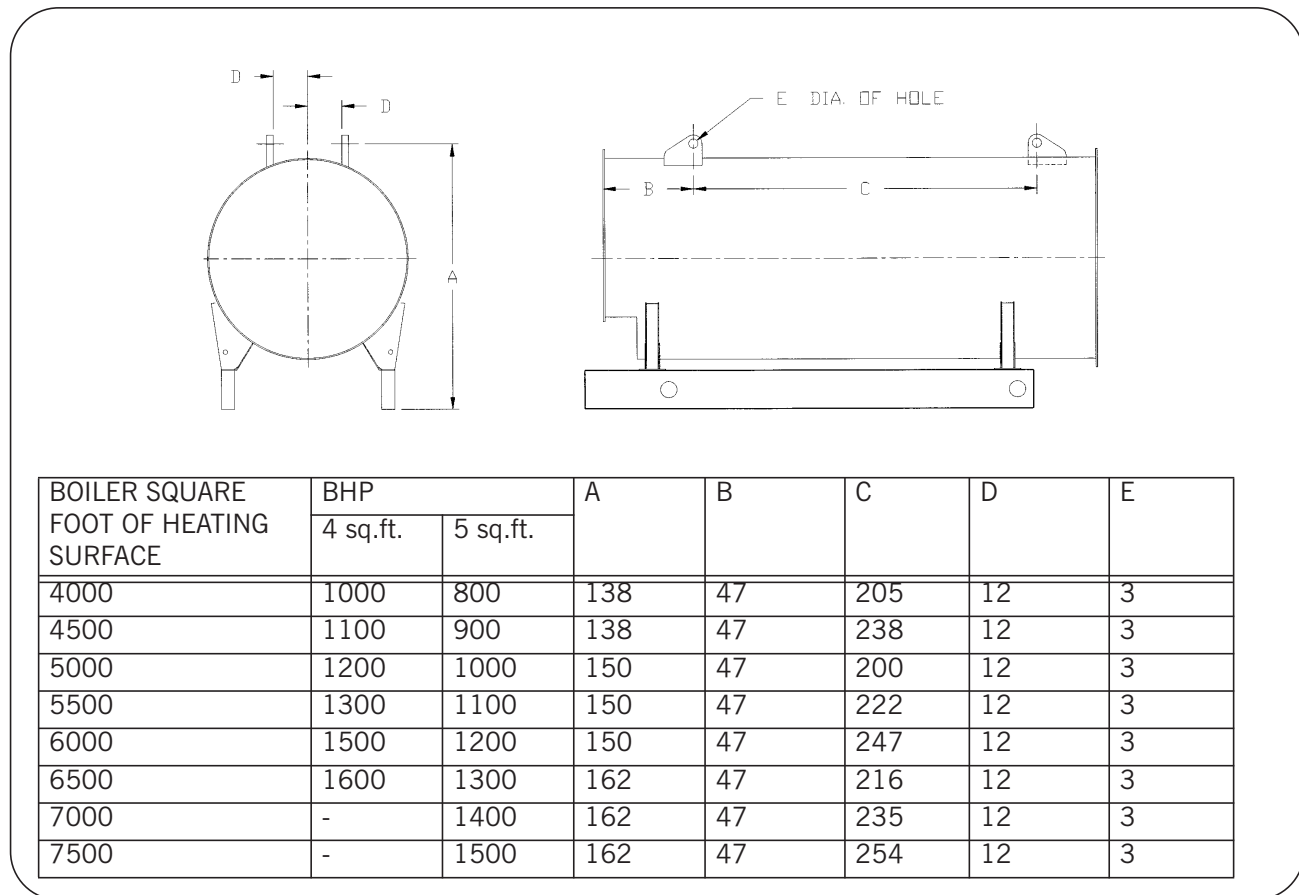
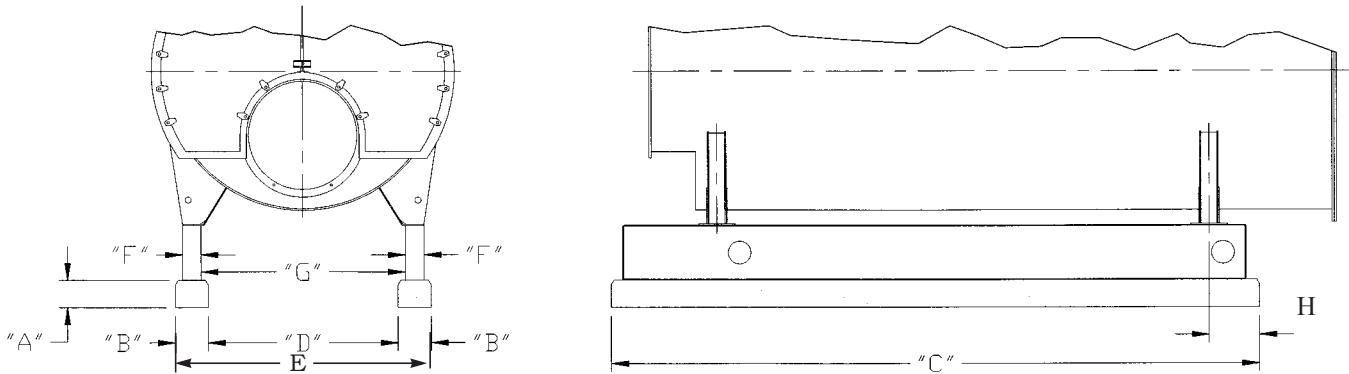

Figure A5-3. CBL Boilers Lifting Lug Location



BOILER SQUARE FOOT OF HEATING SURFACE	BHP		A	B	C	D	E	F	G	H
	4 sq-ft	5 sq-ft								
4000	1000	800	6	12	*	76	100	8	80	12
4500	1100	900	6	12	*	76	100	8	80	12
5000	1200	1000	6	12	*	76	100	8	80	15
5500	1300	1100	6	12	*	76	100	8	80	15
6000	1500	1200	6	12	*	76	100	8	80	15
6500	1600	1300	6	12	*	76	100	8	80	15
7000	-	1400	6	12	*	76	100	8	80	15
7500	-	1500	6	12	*	76	100	8	80	15

NOTE: All numbers in table are in inches.

6-inch high mounting piers recommended for beneath the boiler frame. The use of these piers provides increased inspection accessibility to the piping beneath the boiler and added height for washing down the area beneath the boiler.

The (\*) varies with horsepower rating and burner selection, see Dimension Diagram for job-specific mounting pier length.

**Figure A5-4. CBL Boiler Mounting Piers**

## PERFORMANCE DATA

### Efficiency

Tables A5-4, A5-5, A5-6, A5-7, A5-8, and A5-9 show predicted fuel-to-steam efficiencies (including radiation and convection losses) for Cleaver-Brooks CBL Firtube boilers. For specific efficiencies on firtube boiler offerings not listed here, contact your local Cleaver-Brooks authorized representative.

Cleaver-Brooks offers an industry leading fuel-to-steam boiler efficiency guarantee for CBL Firtube Boilers. The guarantee is based on the fuel-to-steam efficiencies shown in the efficiency tables and the following conditions. The efficiency percent number is only meaningful if the specific conditions of the efficiency calculations are clearly stated in the specification (see Cleaver-Brooks publication CB-7767 for a detailed description of efficiency calculations).

The boiler manufacturer shall guarantee that, at the time of startup, the boiler will achieve fuel-to-steam efficiency (as shown in the tables listed above) at 100% firing

rate (add efficiency guarantees at 25%, 50%, and 75% of rating, if required). If the boiler(s) fail to achieve the corresponding guaranteed efficiency as published, the boiler manufacturer will rebate, to the ultimate boiler owner, five thousand dollars (\$5,000) for every full efficiency point (1.0%) that the actual efficiency is below the guaranteed level. The specified boiler efficiency is based on the following conditions.

1. Fuel specification used to determine boiler efficiency:
  - Natural Gas
    - Carbon,% (wt) = 69.98
    - Hydrogen,% (wt) = 22.31
    - Sulfur,% (wt) = 0.0
    - Heating value, Btu/lb = 21,830
  - No. 2 Oil
    - Carbon,% (wt) = 85.8
    - Hydrogen,% (wt) = 12.7
    - Sulfur,% (wt) = 0.2
    - Heating value, Btu/lb = 19,420
  - No. 6 Oil
    - Carbon,% (wt) = 86.6
    - Hydrogen,% (wt) = 10.9
    - Sulfur,% (wt) = 2.09
    - Heating value, Btu/lb = 18,830
2. Efficiencies are based on ambient air temperature of 80 °F, relative humidity of 30%, and 15% excess air in the exhaust flue gas.
3. Efficiencies are based on the following radiation and convection losses. Firing rate of 25% - 1.2%, 50% - 0.6%, 75% - 0.4%, and 100% - 0.3%.

## ENGINEERING DATA

The following engineering information is provided for CBL Boilers. Additional detail is available from your local Cleaver-Brooks authorized representative.

### Boiler Information

Table A5-12 shows steam volume and disengaging area for CBL boilers.

Table A5-10 lists quantity and outlet size for safety valves supplied on CBL boilers.

Table A5-11 gives recommended steam nozzle sizes on CBL Boilers.

Table A5-13 shows recommended non-return valve sizes for CBL Boilers.

#### Blowdown Water Requirements

Some local codes require blowdown tanks to be constructed in accordance with recommendations of the National Board of Boiler and Pressure Vessel Inspectors.

The National Board's recommendations base the size of the blowdown tank on the removal of at least 4 inches of water from the boiler.

Table A5-14 lists the approximate quantity of water represented by 4 inches of water at normal operating level for Cleaver-Brooks CBL Boilers.

### Burner/Control Information

#### *Burner Characteristics*

Note that altitude correction and burner changes are required for higher altitudes

which may alter dimensions, motor hp and gas pressures. Also 50 Hz applications and low NOx options should be reviewed by the Cleaver-Brooks authorized representative.

### ***Gas-Fired Burners***

Table A5-15 gives gas train connection sizes and gas pressure requirements.

Table A5-16 shows correction factors for gas pressure at elevations over 1000 ft. above sea level.

For oversized or undersized gas trains or altitude above 1,000 feet, contact your local Cleaver-Brooks authorized representative.

### ***Fuel Connections - Gas***

The local gas company should be consulted for requirements and authorization for installation and inspection of gas supply piping. Installation of gas supply piping and venting must be in accordance with all applicable engineering guidelines and regulatory codes. All connections made to the boiler should be arranged so that all components remain accessible for inspection, cleaning and maintenance.

A drip leg should be installed in the supply piping before the connection to the gas pressure regulator. The drip leg should be at least as large as the inlet fitting supplied with the boiler. Consideration must be given to both volume and pressure requirements when choosing gas supply piping size. Refer to the boiler dimension diagram provided by Cleaver-Brooks for the particular installation. Connections to the burner gas train should be made with a union, so that gas train components or the burner may be easily disconnected for inspection or service. Upon completion of the gas piping installation, the system should be checked for gas leakage and tight shutoff of all valves.

### ***Fuel Connections - Oil***

Oil-fired burners are equipped with an oil pump, which draws fuel from a storage tank and supplies pressurized oil to the burner nozzle(s). The burner supply oil pump has a greater capacity than the burner requires for the maximum firing rate. Fuel not delivered to the nozzle is returned to the storage tank. A two-pipe (supply and return) oil system is recommended for all installations. Figure A5-5 shows a typical fuel oil supply arrangement. Oil lines must be sized for the burner and burner supply oil pump capacities.

The burner supply oil pump suction should not exceed 10" Hg. If a transfer pump is used, it must have a pumping capacity at least equal to that of the burner pump(s). Supply pressure to the burner pump should not exceed 3 psig.

A strainer must be installed in the supply piping upstream of the burner supply pump in order to prevent entry of foreign material into the pump, fuel control valves, or burner nozzle(s). The strainer must be sized for the burner supply pump capacity. A strainer mesh of 150 microns (0.005") is recommended.

Install a check valve in the line to prevent draining of the oil suction line when the burner is not in operation. Location of the check valve varies with the system, but usually it is located as close as possible to the storage tank.

Installation of a vacuum gauge in the burner supply line between the burner oil pump and the strainer is recommended. Regular observation and recording of the gauge indication will assist in determining when the strainer needs servicing.

**Boiler Room Information**

Upon completion of the oil piping installation, the system should be checked for oil or air leakage and tight shutoff of all valves.

Figure A5-7 shows typical boiler room length requirements.

Figure A5-8 shows typical boiler room width requirements.

**Stack Support Capabilities**

CBL Boilers can support up to 2000 lbs. without additional support.

CBL Boilers can be reinforced to support up to 3000 lbs.

**Boiler Room Combustion Air**

When determining boiler room air requirements, the size of the room, air flow, and velocity of air must be reviewed as follows:

1. Size (area) and location of air supply openings in boiler room.
  - A. Two (2) permanent air supply openings in the outer walls of the boiler room are recommended. Locate one (1) at each end of the boiler room, preferably below a height of 7 feet. This allows air to sweep the length of the boiler.
  - B. Air supply openings can be louvered for weather protection, but they should not be covered with fine mesh wire, as this type of covering has poor air flow qualities and is subject to clogging by dust or dirt.
  - C. A vent fan in the boiler room is not recommended, as it could create a slight vacuum under certain conditions and cause variations in the quantity of combustion air. This can result in unsatisfactory burner performance.
  - D. Under no condition should the total area of the air supply openings be less than one (1) square foot.
  - E. Size the openings by using the formula:

$$\text{Area (sq-ft)} = \text{CFM/FPM}$$

2. Amount of air required (cfm).
  - A. Combustion Air = Rated bhp x 8 cfm/bhp.
  - B. Ventilation Air = Maximum bhp x 2 cfm/bhp or a total of 10 cfm/bhp - up to 1000 feet elevation. Add 3 percent more per 1000 feet of added elevation.
3. Acceptable air velocity in Boiler Room (fpm).
  - A. From floor to (7) foot height - 250 fpm.
  - B. Above (7) foot height - 500 fpm.

Example: Determine the area of the boiler room air supply openings for (1) 1000 hp boiler at 800 feet altitude. The air openings are to be 5 feet above floor level.

- Air required:  $1000 \times 10 = 10000$  cfm (from 2B above).
- Air velocity: Up to 7 feet = 250 fpm (from 3 above).
- Area Required:  $\text{Area} = \text{cfm/fpm} = 10000/250 = 40$  Sq-ft total.
- Area/Opening:  $40/2 = 20$  sq-ft/opening (2 required).

**Notice**

*Consult local codes, which may supersede these requirements.*

**Stack/Breeching Size Criteria**

The design of the stack and breeching must provide the required draft at each boiler flue gas outlet. Proper draft is critical to burner performance.

Although constant pressure at the flue gas outlet of the CBL is not required, it is necessary to size the stack/breeching to limit flue gas pressure variation. The allowable pressure range is  $-0.50''$  W.C. to  $+0.50''$  W.C. The maximum pressure variation at any firing rate for the boiler is  $0.50''$  W.C.

The low NOx option allowable pressure range is -0.25" W.C. to +0.25" W.C. The maximum pressure variation at any firing rate for the boiler is 0.25"W.C.

For additional information, please review Section I4, General Engineering Data (Stacks) and Section F, Stacks. Stack and breeching sizes should always be provided by a reputable stack supplier who will design the stack and breeching system based on the above criteria. Your local Cleaver-Brooks authorized representative is capable of assisting in your evaluation of the stack/breeching design.

**Table A5-4. Predicted Fuel-to-Steam Efficiencies (%) CBL Boilers- 125 psig, Natural Gas, 5sq. ft./BHP, 4 Pass**

BOILER HP	FIRING RATE (%)			
	25	50	75	100
800	82.0	82.3	82.7	82.5
900	82.3	82.0	82.5	82.5
1000	82.0	82.6	82.7	82.6
1100	82.3	82.7	82.7	82.7
1200	82.2	83.0	83.2	83.2
1300	82.5	82.8	83.0	83.0
1400	82.3	82.3	82.8	82.8
1500	82.0	83.0	83.0	83.0

**Table A5-5. Predicted Fuel-to-Steam Efficiencies (%) CBL Boilers- 125 psig, No. 2 Oil, 5sq. ft./BHP, 4 Pass**

BOILER HP	FIRING RATE (%)			
	25	50	75	100
800	85.2	85.9	85.9	86.0
900	85.3	85.8	86.0	86.0
1000	85.8	86.0	86.0	86.2
1100	85.5	85.6	85.6	86.0
1200	85.8	86.0	86.3	86.5
1300	85.3	86.0	86.4	86.6
1400	85.9	86.0	86.4	86.5
1500	86.0	86.6	86.5	86.6

**Table A5-6. Predicted Fuel-to-Steam Efficiencies (%) CBL Boilers- 125 psig, No. 6 Oil, 5sq. ft./BHP, 4 Pass**

BOILER HP	FIRING RATE (%)			
	25	50	75	100
800	86.5	86.0	86.5	86.8
900	86.6	86.5	86.5	86.9
1000	86.5	86.6	86.5	86.8
1100	86.5	86.7	86.6	86.9
1200	86.5	87.0	87.0	87.0
1300	86.3	86.6	87.0	87.0
1400	86.0	86.5	86.8	86.7
1500	86.0	86.5	86.8	86.6

**Table A5-7. Predicted Fuel-to-Steam Efficiencies (%) CBL Boilers- 125 psig, Natural Gas, 4 sq. ft./BHP, 3 Pass**

BOILER HP	FIRING RATE (%)			
	25	50	75	100
1000	81.4	81.5	81.5	81.5
1100	81.3	81.6	82.0	82.0
1200	81.2	81.4	82.0	82.0
1300	81.0	81.3	81.6	82.0
1400	81.0	81.3	81.4	81.8
1500	81.0	81.4	81.4	81.9

**Table A5-8. Predicted Fuel-to-Steam Efficiencies (%) CBL Boilers- 125 psig, No. 2 Oil, 4 sq. ft./BHP, 3 Pass**

BOILER HP	FIRING RATE (%)			
	25	50	75	100
1000	84.8	85.0	85.0	85.0
1100	84.7	85.0	85.0	85.0
1200	85.0	85.2	85.4	85.2
1300	85.0	85.0	84.8	85.5
1400	85.0	85.6	84.8	85.5
1500	85.0	85.5	84.9	85.6

**Table A5-9. Predicted Fuel-to-Steam Efficiencies (%) CBL Boilers- 125 psig, No. 6 Oil, 4 sq. ft./BHP, 3 Pass**

BOILER HP	FIRING RATE (%)			
	25	50	75	100
1000	86.2	86.2	85.8	85.6
1100	86.3	86.4	86.1	85.9
1200	86.2	86.2	85.8	86.0
1300	86.0	86.4	86.1	85.8
1400	86.0	86.4	86.0	85.8
1500	86.0	86.3	86.2	85.9

**Table A5-10. CBL Steam Boiler Safety Valve Outlet Size**

VALVE SETTING	15 PSIG STEAM		150 PSIG STEAM		200 PSIG STEAM		250 PSIG STEAM	
BOILER HP	NO. OF VALVES REQ'D	OUTLET SIZE ("FPT)	NO. OF VALVES REQ'D	OUTLET SIZE ("FPT)	NO. OF VALVES REQ'D	OUTLET SIZE ("FPT)	NO. OF VALVES REQ'D	OUTLET SIZE ("FPT)
800	-	-	2	1 - 3 1 - 4	2	1 - 2 1/2 1 - 3	2	2 1/2
900	-	-	2	1 - 3 1 - 4	2	3	2	1 - 2 1/2 1 - 3
1000	3	2 - 8 1 - 6	2	4	2	3	2	1 - 2 1/2 1 - 3
1100	3	2 - 8 1 - 6	2	4	2	1 - 3 1 - 4	2	3
1200	2	8	2	4	2	1 - 3 1 - 4	-	-
1300	3	8	3	2 - 3 1 - 4	3	1 - 2 1/2 2 - 3	-	-
1400	3	8	3	1 - 3 2 - 4	3	3	-	-
1500	3	8	3	1 - 3 2 - 4	3	3	-	-

NOTES:  
 Table A11-8 only applies to 5 Sq Ft/BHP units.  
 Valve manufacture is Kunkle.  
 Valve requirements can vary with special pressure settings.

**Table A5-11. CBL Recommended Steam Nozzle Size**

BOILER HP											
OPERATING PRESSURE PSIG	800	900	1000	1100	1200	1300	1400	1500	1600	1700	1800
12	18	18	20	20	24	24	24	24	24	24	24
30	14	16	16	16	18	18	18	20	20	20	20
50	12	12	12	14	16	16	16	16	16	16	16
75	10	10	12	12	12	12	12	14	14	14	14
100	10	10	10	10	12	12	12	12	12	12	14
125	8	10	10	10	10	10	12	12	12	12	12
150	8	8	8	10	10	10	10	10	10	10	12
200	8	8	8	8	10	10	10	10	10	10	10
225	6	8	8	8	8	10	10	10	10	10	10

NOTES:  
 Steam nozzle sizes given in inches.  
 All standard steam nozzle sizes for the 150 psig design pressure or greater are the same as 125 psig operating pressure on the above table. To increase or decrease the standard size, request the change with your local Cleaver-Brooks authorized representative.



**Table A5-12. CBL Steam Volume and Disengaging Areas**

BOILER SQUARE FOOT OF HEATING SURFACE	BHP		STEAM VOLUME (CU-FT)	STEAM RELIEVING AREA (SQ-IN)
	4 SQ.FT.	5 SQ.FT.	HIGH PRESSURE (A)	HIGH PRESSURE (A)
4000	1000	800	155	20566
4500	1100	900	174	23105
5000	1200	1000	250	24141
5500	1300	1100	273	26372
6000	1500	1200	300	28908
6500	1600	1300	352	28918
7000	-	1400	379	31079
7500	-	1500	405	33242

NOTES:  
 Based on normal water level.  
 Values are based on standard controls. Optional controls may result in different values.  
 A. Based on 150 psig design pressure.

**Table A5-13. CBL Recommended Non-Return Valve Size**

BOILER HP	CAPACITY LBS.PER HR.	OPERATING PRESSURE							
		50	75	100	125	150	175	200	225
900	31050	8	6	6	6	6	6	6	5
1000	34500	8	6*	6	6	6	6	6	5
1100	37950	8	8	6	6	6	6	6	6
1200	41400	8	8	8	6	6	6	6	6
1300	44850	8	8	8	8	6	6	6	6
1400	48300	8	8	8	8	8	6	6	6
1500	51750	8	8	8	8	8	8	6	6
1600	55200	10	10	8	8	8	8	8	6

NOTE:  
 Valve sizes (300# flanges) given in inches.  
 Standard non-return valve selections limited to a maximum 2 to 1 turndown (50% of full boiler output); selection based on typical valve sizing recommendations. For final valve selection contact your authorized C-B representative. For high turndown applications see Boiler Book Section I3, Table I3-3.  
 \*Indicates pressure drop of less than 7.5 psig. All other selections are less than 6 psig pressure drop.

**Table A5-14. CBL Blowdown Tank Sizing Information**

BOILER SQUARE FOOT OF HEATING SURFACE	BHP		WATER (GAL)
	4 SQ.FT.	5 SQ.FT.	
4000	1000	800	356
4500	1100	900	400
5000	1200	1000	418
5500	1300	1100	460
6000	1500	1200	500
6500	1600	1300	500
7000	-	1400	538
7500	-	1500	575

NOTE: Quantity of water removed from boiler by lowering normal water line 4".  
 Optional level controls can alter water quantities.

**Table A5-15. CBL gas train connection size and gas pressure requirements**

Boiler HP	4 ft <sup>2</sup> /bhp							
	3 pass				4 pass			
	std		30 ppm		std		30 ppm	
	Gas train connection	Pressure required	Gas train connection	Pressure required	Gas train connection	Pressure required	Gas train connection	Pressure required
1000	2.5	8.2	2.5	8.3	2.5	8.1	2.5	8.2
1100	3	5.4	3	5.4	3	5.4	3	5.6
1200	3	6.3	3	6.3	3	6.3	3	6.4
1300	3	7.2	3	7.3	3	7.2	3	7.3
1400	3	8.4	3	8.5	3	8.3	3	8.5
1500	4	5.4	4	5.5	4	5.6	4	5.8

Boiler HP	4.5 ft <sup>2</sup> /bhp							
	3 pass				4 pass			
	std		30 ppm		std		30 ppm	
	Gas train connection	Pressure required	Gas train connection	Pressure required	Gas train connection	Pressure required	Gas train connection	Pressure required
900	2.5	7.4	2.5	7.4	2.5	7.3	2.5	7.4
1000	2.5	8.2	2.5	8.3	2.5	8.1	2.5	8.2
1100	3	5.3	3	5.4	3	5.3	3	5.4
1200	3	6.3	3	6.3	3	6.2	3	6.4
1300	3	7.2	3	7.3	3	7.2	3	7.3
1400	3	8.4	3	8.4	3	8.2	3	8.3
1500	4	5.4	4	5.5	4	5.4	4	5.6

Boiler HP	5 ft <sup>2</sup> /bhp							
	3 pass				4 pass			
	std		30 ppm		std		30 ppm	
	Gas train connection	Pressure required	Gas train connection	Pressure required	Gas train connection	Pressure required	Gas train connection	Pressure required
800	2.5	6.0	2.5	6.1	2.5	5.9	2.5	6.0
900	2.5	7.4	2.5	7.4	2.5	7.3	2.5	7.4
1000	2.5	8.2	2.5	8.2	2.5	7.9	2.5	8.0
1100	3	5.3	3	5.4	3	5.3	3	5.4
1200	3	6.3	3	6.3	3	6.2	3	6.3
1300	3	7.2	3	7.2	3	7.1	3	7.2
1400	3	8.4	3	8.4	3	8.2	3	8.3
1500	4	5.4	4	5.5	4	5.4	4	5.6

Notes: 3 pass boilers are based on 80% efficiency  
 4 pass boilers are based on 82% efficiency  
 Pressure shown is minimum required and is listed as psi  
 Incoming pressure is not to exceed 10 psi  
 Ultra Low Nox (9 and 15ppm) are handled on a case by case basis

Table is based on Siemens gas train, which includes a regulating actuator.

**Table A5-16. Altitude Correction for Gas**

ALTITUDE (FT)	CORRECTION FACTOR	ALTITUDE (FT)	CORRECTION FACTOR
1000	1.04	6000	1.25
2000	1.07	7000	1.30
3000	1.11	8000	1.35
4000	1.16	9000	1.40
5000	1.21	-	-

To obtain minimum required gas pressure at altitudes above 700 feet, multiply the pressure by the listed factors:  
 inches WC x 0.577 = oz/sq-in.  
 oz/sq-in x 1.732 = inches WC.  
 inches WC x 0.0361 = psig.  
 oz/sq-in x 0.0625 = psig.  
 psig x 27.71 = Inches WC.  
 psig x 16.0 = oz/sq-in.

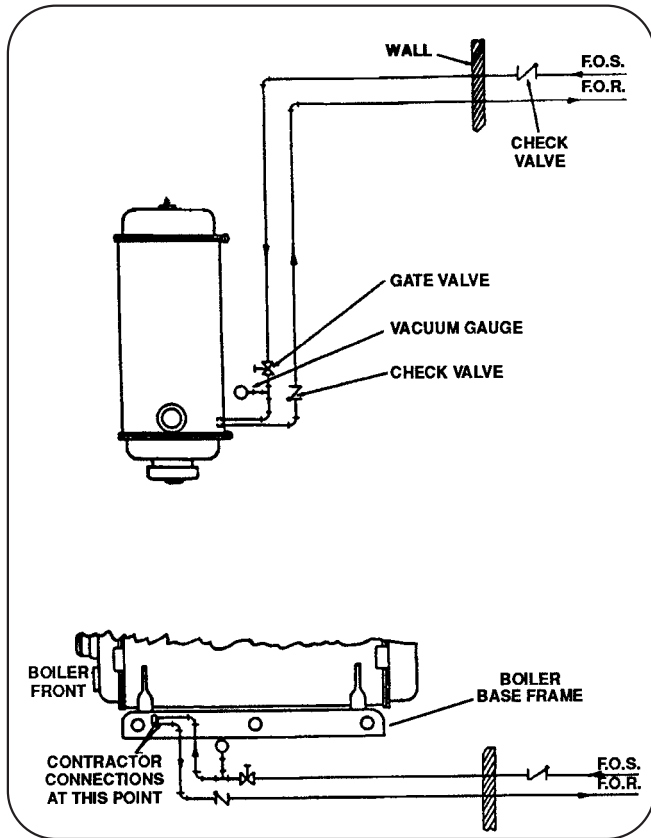

Figure A5-5. No. 2 Oil Piping, Single Boiler Installation, Oil Pump Integral With Boiler

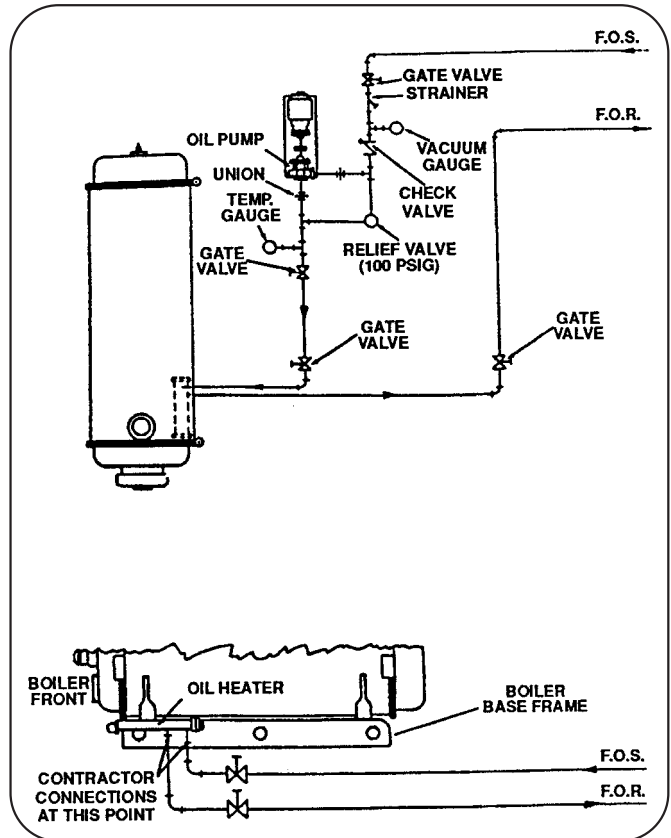
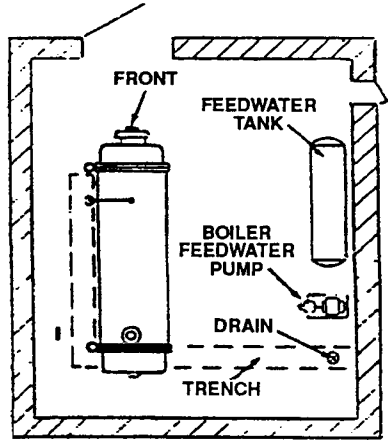

Figure A5-6. No. 6 Oil Piping, Single Boiler Installation, Remote Oil Pumps

BOILER SQUARE FOOT OF HEATING SURFACE	BHP		A	B
	4 sq.ft.	5 sq.ft.		
4000	1000	800	610	484
4500	1100	900	670	514
5000	1200	1000	606	489
5500	1300	1100	654	513
6000	1500	1200	700	536
6500	1600	1300	642	515
7000	-	1400	680	534
7500	-	1500	718	553

NOTES:  
 A = Minimum length based on removing tubes in the boiler room.  
 B = Minimum length based on removing tubes through a wall opening.

Figure A5-7. Boiler Room Length (Typical Layout)



DRAWING A

1. Shortest boiler room length (Dwg A) is obtained by allowing for possible future tube replacement from front of boiler through a window or doorway. Allowance is only made for minimum door swing at each end of the boiler. This arrangement provides sufficient aisle space at the front of the boiler but a "tight" space condition at the rear.

If space permits, approximately 1.5 additional feet should be allowed at the rear for additional aisle and working space.

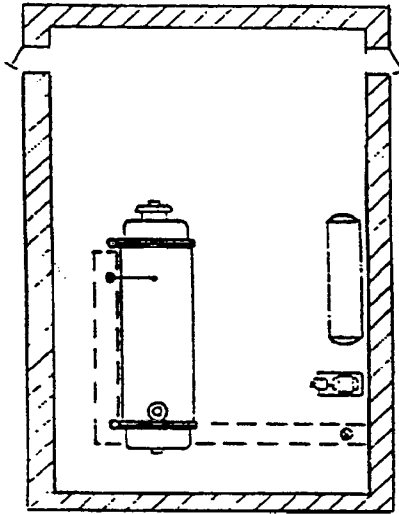

DRAWING B

2. Next shortest boiler room length (Dwg B) is obtained by allowing for possible future tube replacement from the front of the boiler. Allowance is only made for minimum door swing at the rear.

If space permits, approximately 1.5 additional feet should be allowed at the rear for additional aisle and working space.

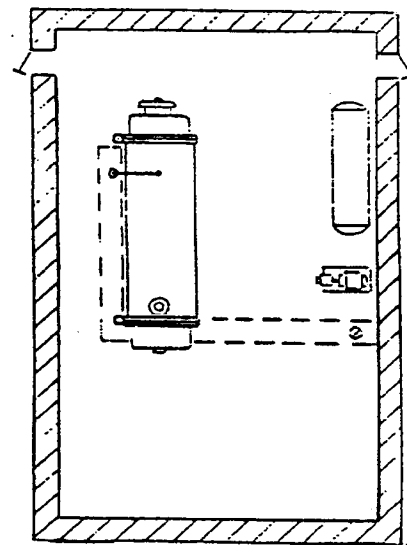

DRAWING C

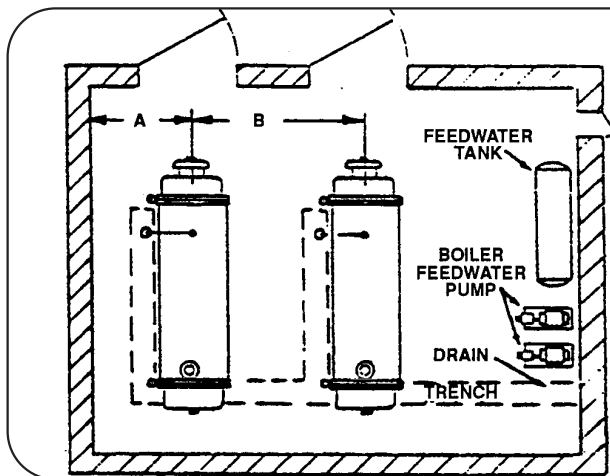

Boiler Square Foot of Heating Surface	4000-4500	5000-6000	6500-7500
Dimension A (inches)	117	123	129
Dimension B (inches)	198	210	222

Figure A5-8. Boiler Room Width (Typical Layouts)